

# Build a 1:22.5-scale Firehouse N<sup>o</sup>1

Plan set #31-  
reprise

by Ted Stinson | Wiscasset, Maine

This is a reprint of plan set #31, originally published in the February 1998 issue of *Garden Railways*.

\* \* \*

This is a generic large-scale firehouse. Its architecture is typical of that of early 1900s New England, and this modest, one-stall structure would fit the needs of most small towns. If high-quality exterior paints are used, the structure will stand up to outdoor use just as well as the prototype did. For the most part, the model and the prototype are made of the same materials.

## Construction

The model can be built from materials in many hobby shops. Unless you work in balsa wood, power tools will almost certainly be required. If the model is to be left outdoors, close attention must be paid to sealing it and painting it with exterior-grade paint.

Begin with the base. Cut this from a single piece of  $\frac{3}{4}$ " x  $7\frac{3}{4}$ " x  $12\frac{1}{8}$ " plywood. Fill any cavities, seal the base, and paint it gray.

Make two sides from pieces of  $\frac{1}{4}$ " x 6" x  $\frac{1}{4}$ " plywood. Cut the window openings, then sheath one side of each piece with  $\frac{1}{2}$ "-thick x  $\frac{1}{4}$ "-spaced scribed wood. Make the ends from two pieces of  $\frac{1}{4}$ " x  $8\frac{1}{2}$ " x  $10\frac{1}{2}$ " plywood. Cut out the windows and, in one end, the main door opening. Sheath the ends with the same scribed wood.

Now cut a length of  $\frac{3}{4}$ "-square stick, about 25" long. Using a table saw, cut  $\frac{1}{8}$ " x  $\frac{1}{4}$ " grooves on two sides, then cut the stick into four pieces, each 6" long. Cut two pieces of  $\frac{1}{4}$ " x  $1\frac{1}{2}$ " stock, each  $11\frac{1}{2}$ " long, and four more, each  $6\frac{1}{8}$ " long. Bevel one end of the  $6\frac{1}{8}$ " pieces at a 45° angle. Using these pieces and a piece of  $\frac{1}{4}$ "-square x  $11\frac{1}{2}$ "-long stock, assemble the basic firehouse.

If you intend to detail the interior (I did not), make up a second floor from  $\frac{1}{4}$ " x  $6\frac{1}{2}$ " x  $9\frac{1}{2}$ " plywood, notching the corners to fit.

Locate the second floor about  $4\frac{1}{2}$ " above the foundation and glue it in place.

Cut two pieces of  $\frac{1}{8}$ " plywood, each  $6\frac{1}{2}$ " x  $11\frac{3}{4}$ ". Glue these in place to form the roof, but do not overlap them at the peak. Instead, use a piece of  $\frac{3}{16}$ "-square to form the ridge.

Before gluing the ridge in place, make the bell tower. In assembling the tower, drill a  $\frac{1}{16}$ "-diameter hole for the cotterpin that holds the bell, but do not fit the pin and bell in place until the final assembly. Fit and glue the bell tower in place on the roof, then add the ridge piece. Cut, fit, and glue  $\frac{1}{8}$ " x  $\frac{1}{4}$ " stripwood under the eaves on the front, sides, and rear. Add the  $\frac{1}{16}$ " x  $\frac{1}{4}$ " stripwood trim around the double door in front.

From a standard 2" x 4", cut a block  $5\frac{1}{4}$ " long, with one end cut at a 45° angle. Sheath this with scribed wood to form the shed in back. Make the roof from  $\frac{1}{8}$ " x  $2\frac{1}{2}$ " x 4" plywood, beveled on one side. Cut, fit, and glue  $\frac{1}{8}$ "-square stripwood under the eaves. Glue this shed to the back of the firehouse on the centerline of the structure.

## Finishing

The building is now ready to be painted. Seal it with one coat of clear lacquer, followed by two spray coats of flat white. Allow it to dry for 24 hours, then hand paint the red trim. You will probably need two coats of trim paint. When the paint has dried, shingle the house, shed, and bell tower. Use 1"-wide strips of black poster board slotted at 1" intervals. Begin by gluing a piece of  $\frac{1}{2}$ "-wide poster board along the bottom edge of each roof surface as a starter strip. Then add the shingle strips just as you would real shingles. When the shingling is done, the roof is ready to be sealed. Apply three coats of exterior-grade polyurethane varnish. Gently brush it in all directions so it coats between and underneath each tab.

Make six windows and one door from stripwood that has been sanded and primed.

When they are finished, prepaint them red. When the paint has dried, glue clear plastic to the backs of the window, then glue and pin the windows and door in place.

Make the smokestack using the plan as a guide. Prepaint this aluminum when dry, then fit and glue it in place. This will require that you drill a  $\frac{3}{8}$ "-diameter hole in the back end for the lower end of the smokestack. Locate and drill a  $\frac{3}{4}$ "-diameter pilot hole in the eaves for the escutcheon pin.

Build the two front doors and paint them red. When they are dry, drill  $\frac{1}{16}$ "-diameter holes in the house and foundation for the hinge pins. When the doors are operating satisfactorily, the firehouse can be permanently glued and screwed to the foundation. It will be necessary to fit stops behind the doors to prevent them from swinging too far in.

Now make the gutters and drain pipes. Use  $\frac{1}{4}$ " x  $\frac{5}{16}$ " stripwood for the gutters. Prepaint them red before pinning them in place. Make the drain pipes from  $\frac{1}{8}$ "-diameter soft aluminum wire. Drill holes in the gutter for the drains. Make U-bolts from .03"-diameter wire to hold the drains against the corner posts. Paint the barrels red and locate them beneath the drains. Fit the bell in the cupola, and your firehouse is complete.

\* \* \*

This reprint is an online supplement to the June 2010 issue of *Garden Railways* magazine. To purchase previously published paper plans, see the list of those available at [www.sidestreet.info](http://www.sidestreet.info)

\* \* \*

© 2010 by *Garden Railways* and Northeast Narrow Gauge. These drawings may be reproduced by individual modelers for their own personal use. Copying for any commercial use or for distribution is prohibited without written consent from the publisher.

## Are you working in a different scale?

- If you are working in 1:24 scale, reduce these drawings to 94%.
- If you are working in 1:20.3 scale, enlarge these drawings to 111%.
- If you are working in 16mm scale (1:19), enlarge these drawings to 118%.
- If you are working in  $\frac{1}{8}$ " scale (1:13.7) enlarge these drawings to 164%.

front view (50%)

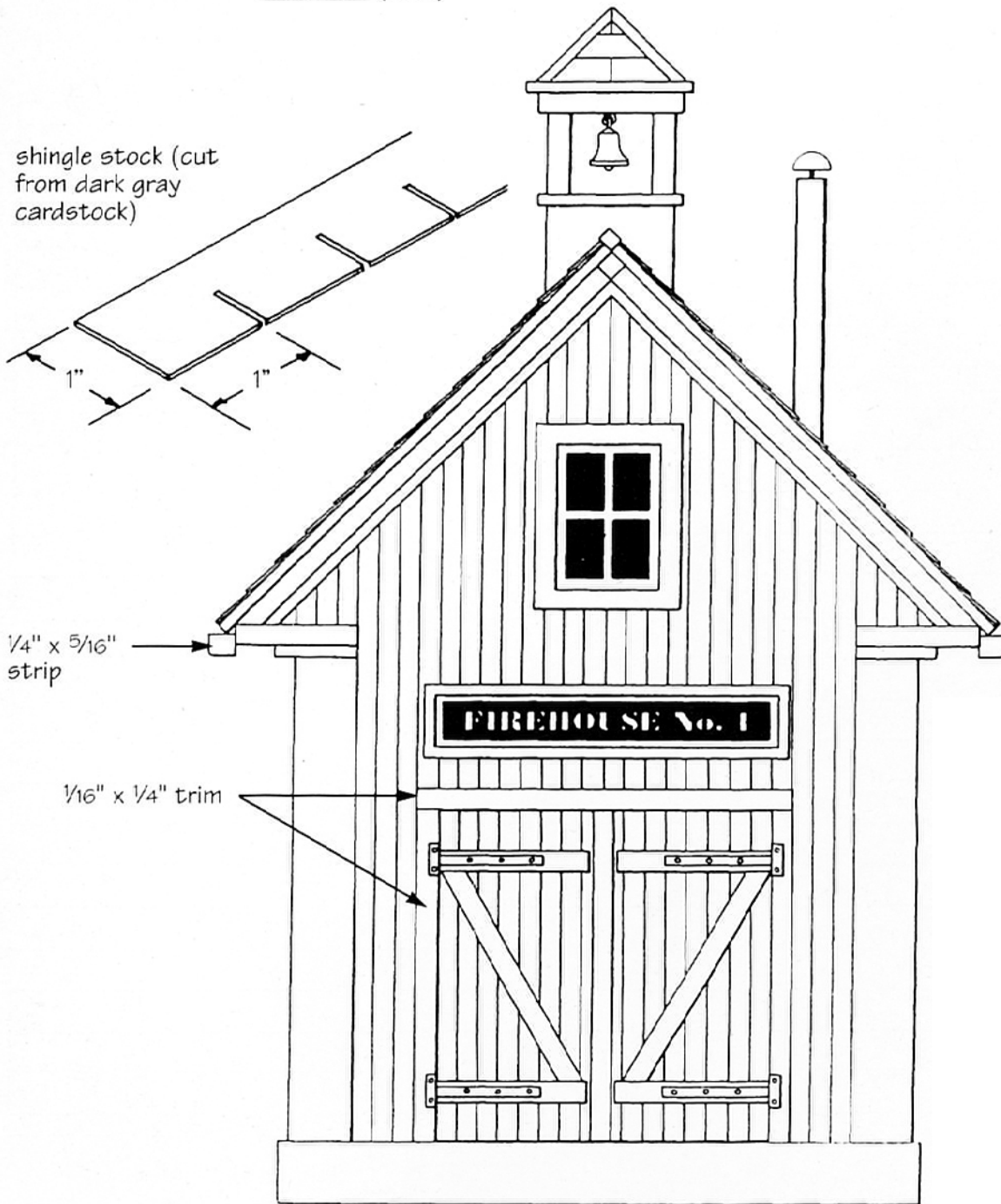

firehouse detail

side view (50%)

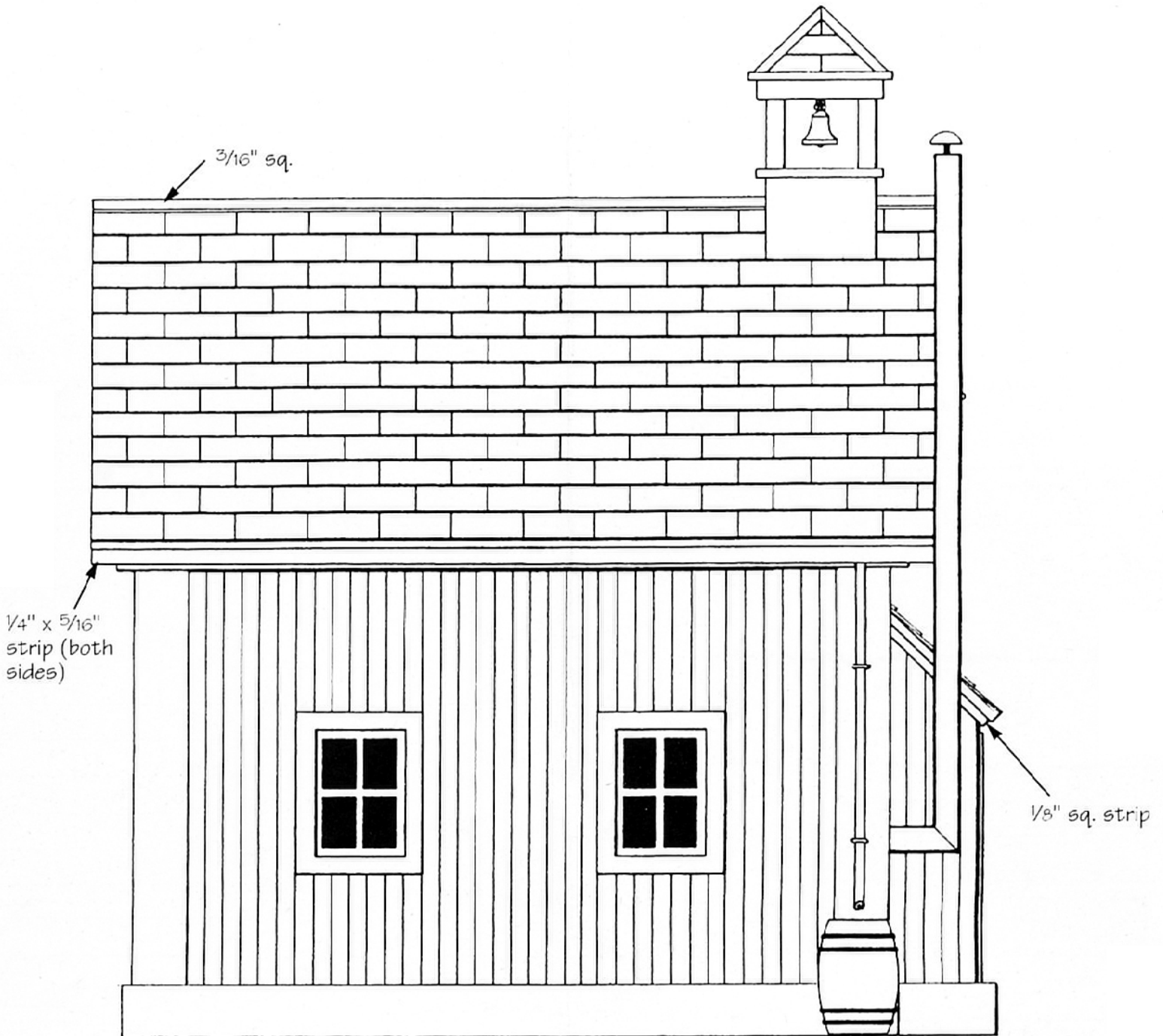

rear view (50%)

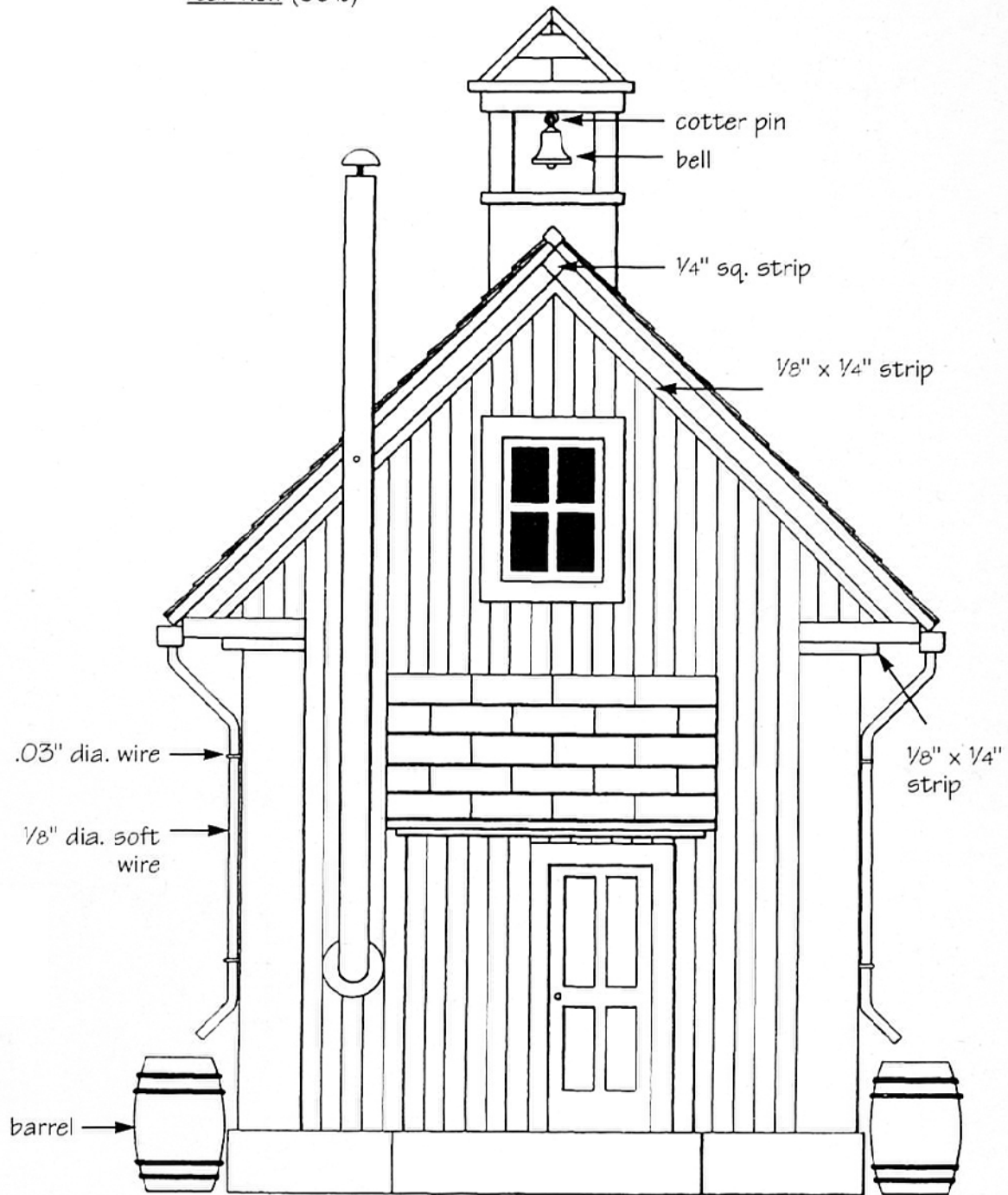

sign

# FIREHOUSE No. 1

sign construction

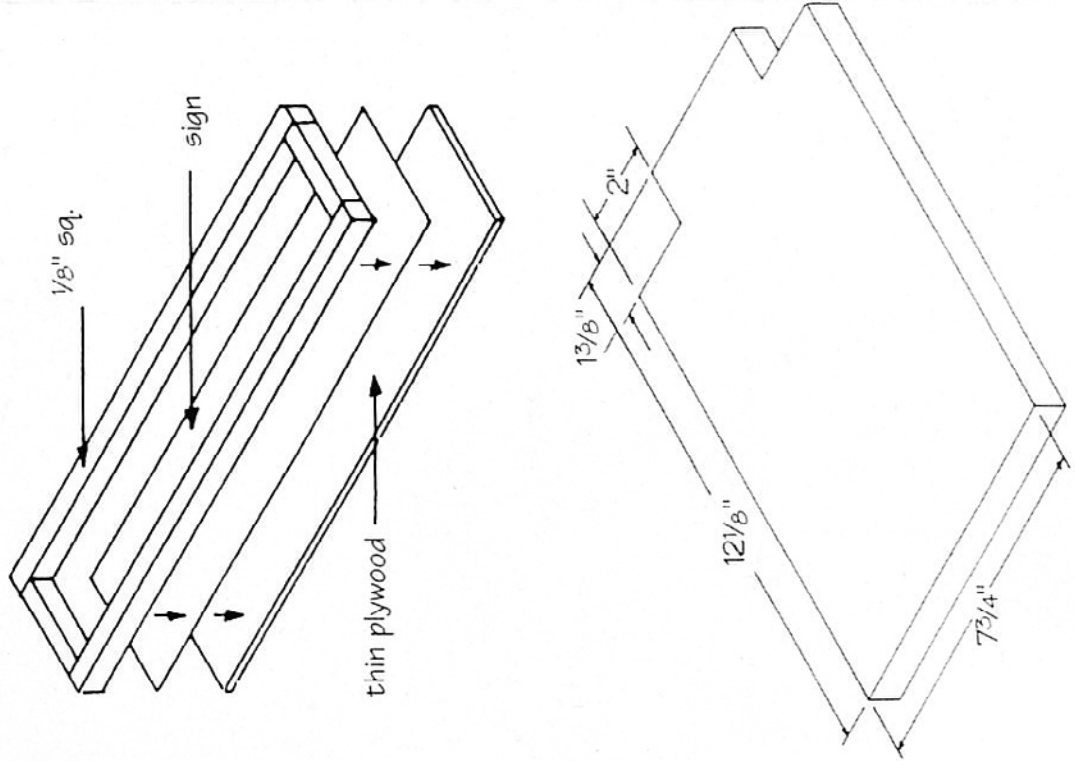

firehouse detail

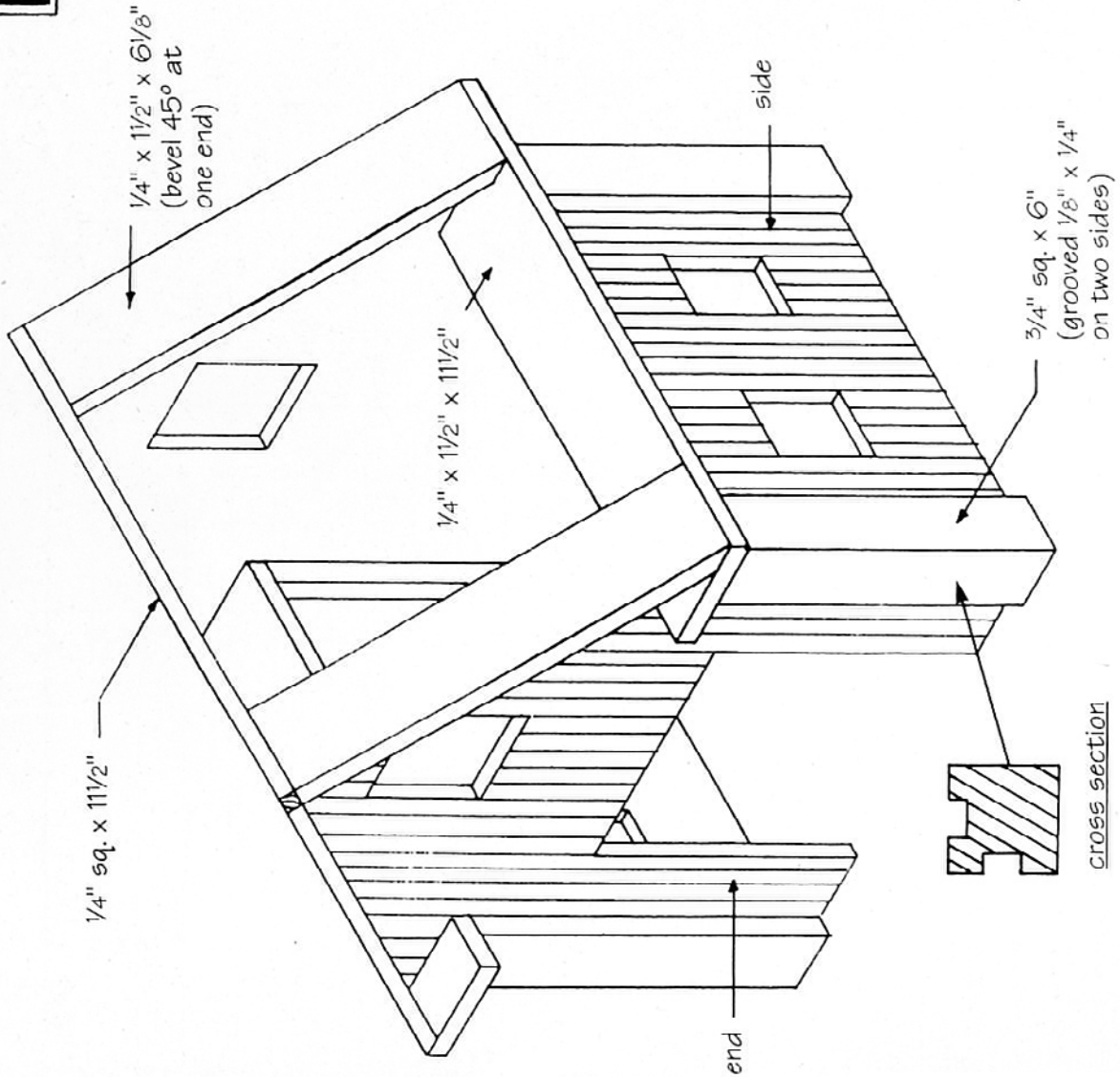

firehouse end (make 2)

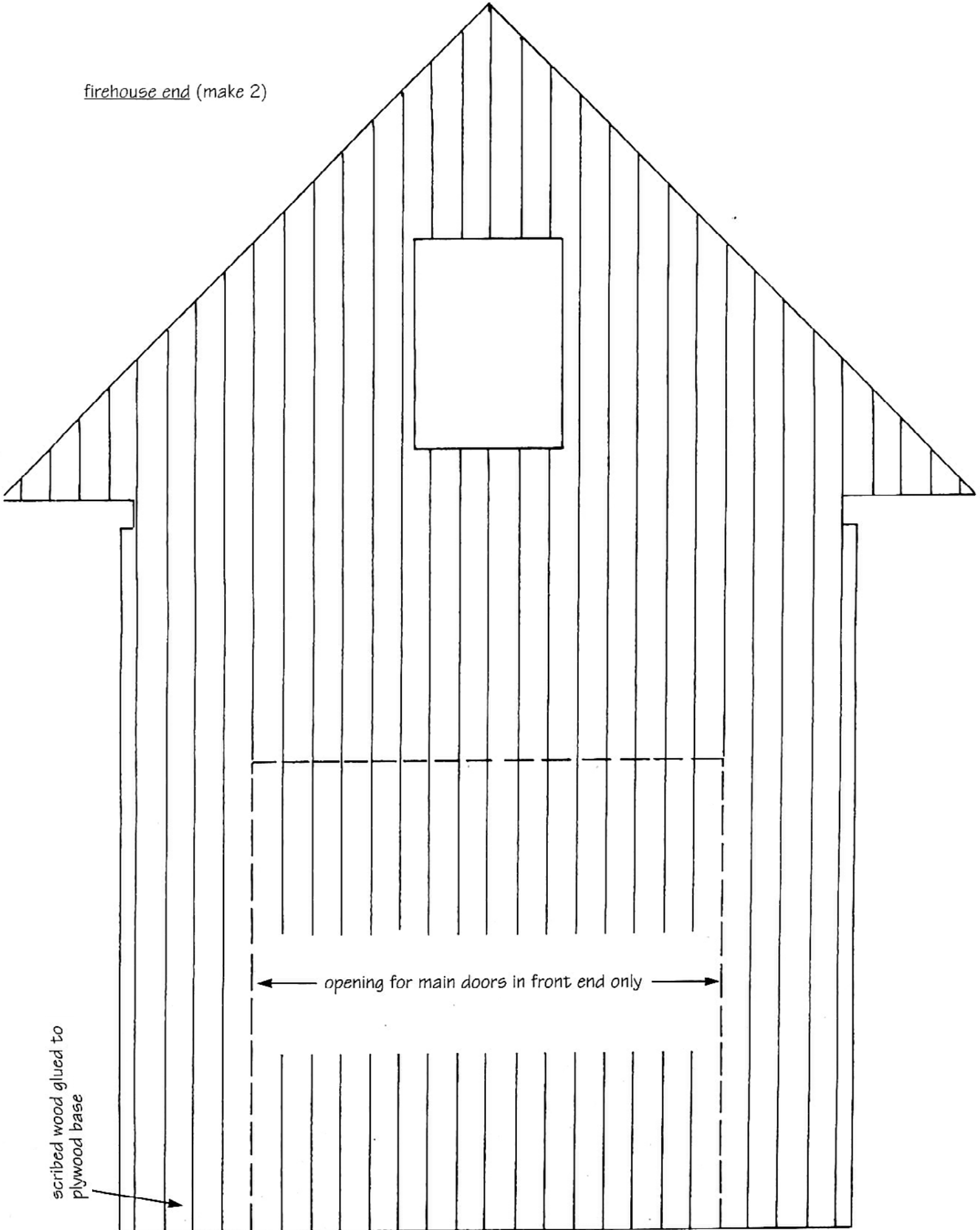

scribed wood glued to plywood base

opening for main doors in front end only

bell tower

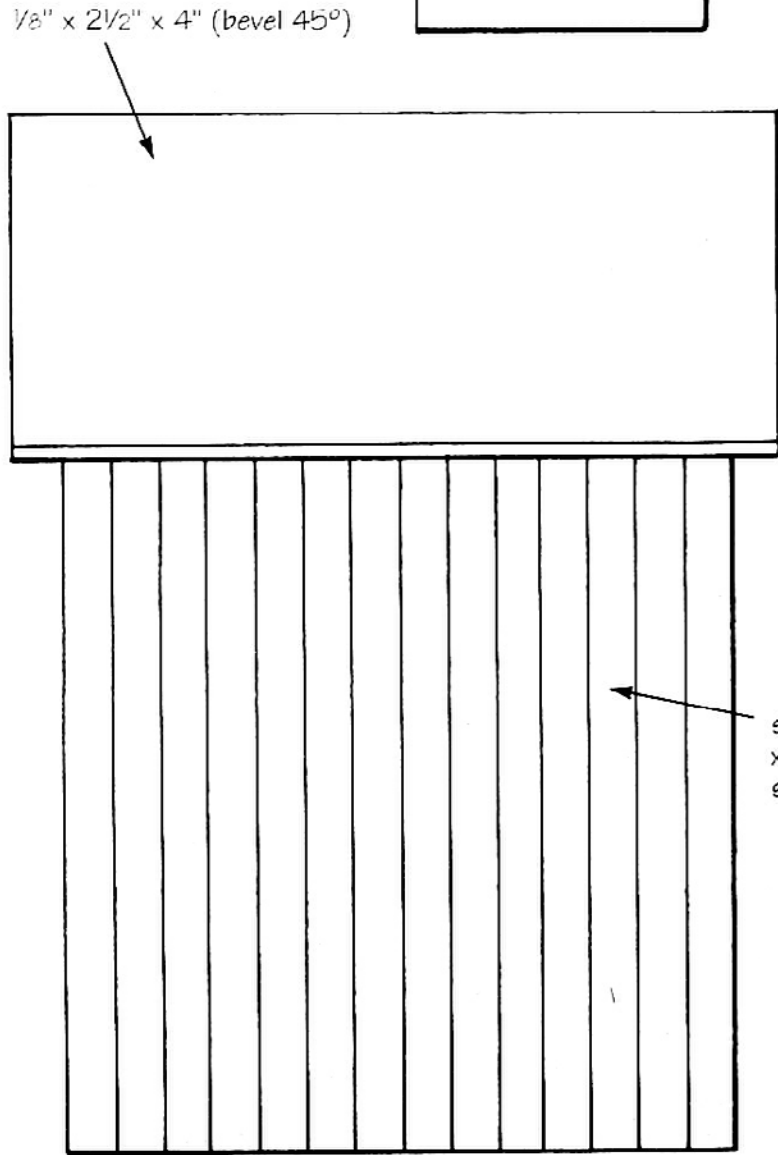
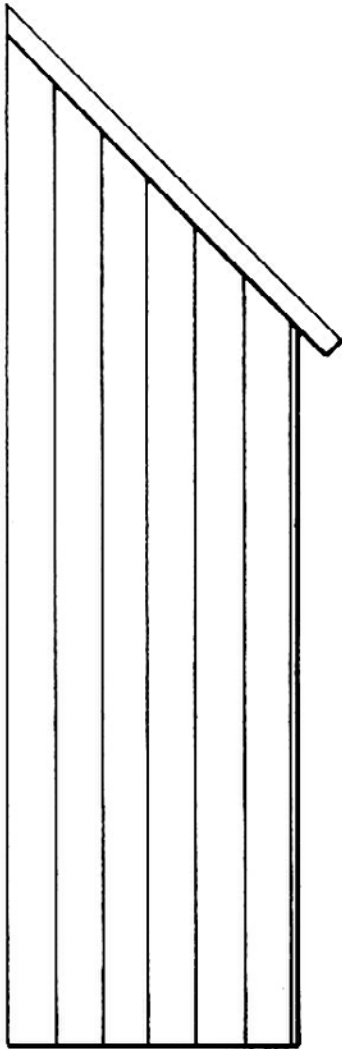
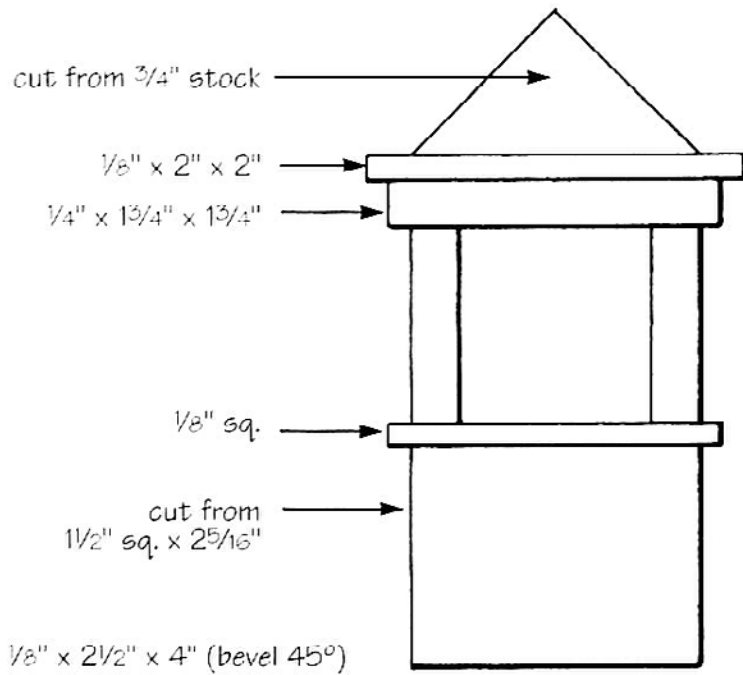
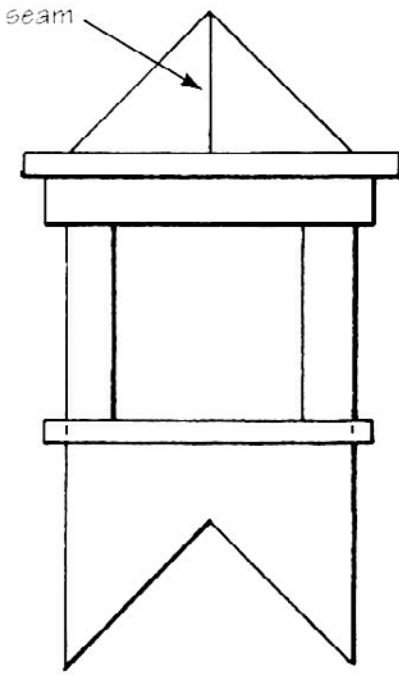

firehouse side (make 2)

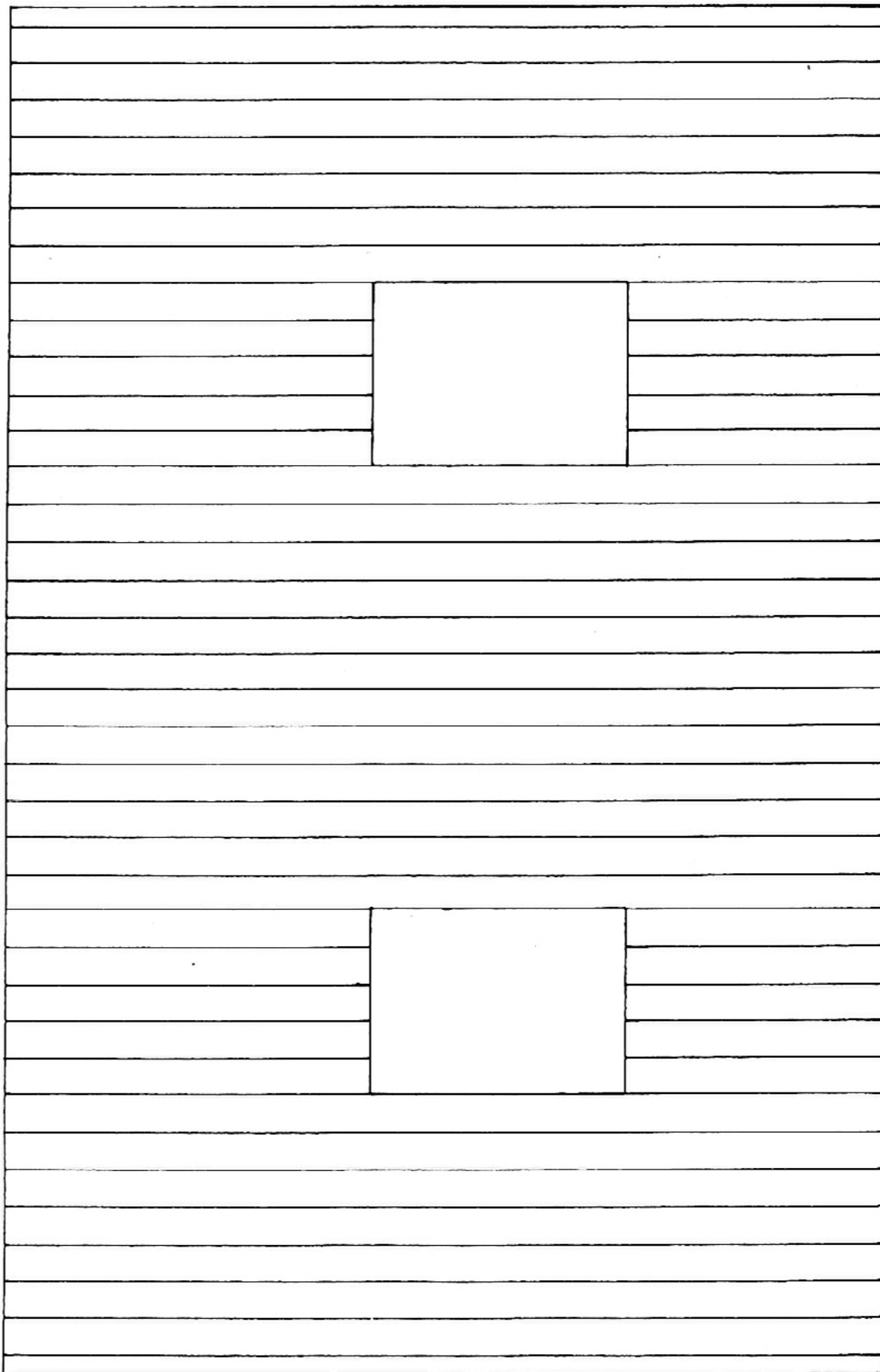

scribed wood glued to plywood base





front doors (make 1 set)

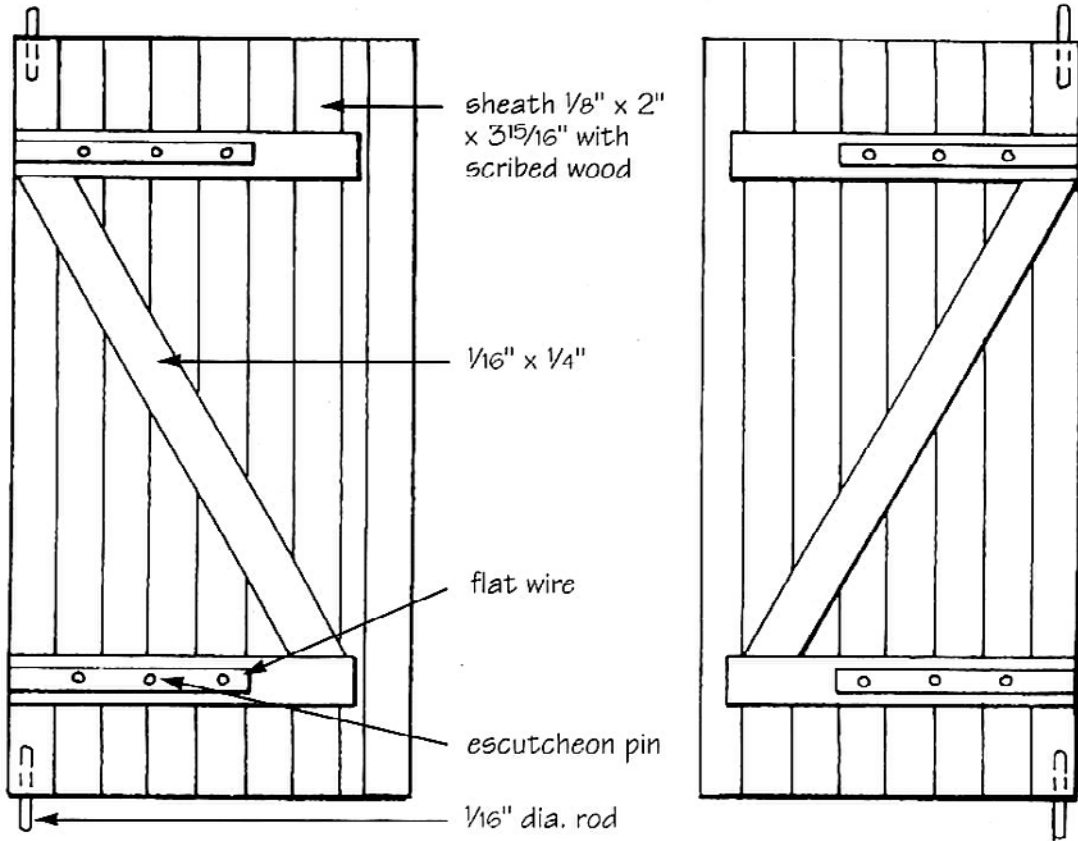

door (make 1)

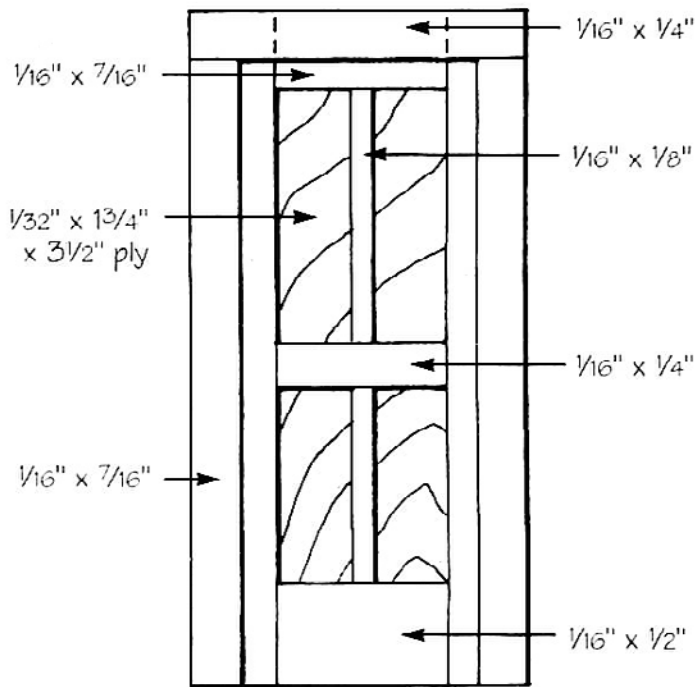

window (make 6)

