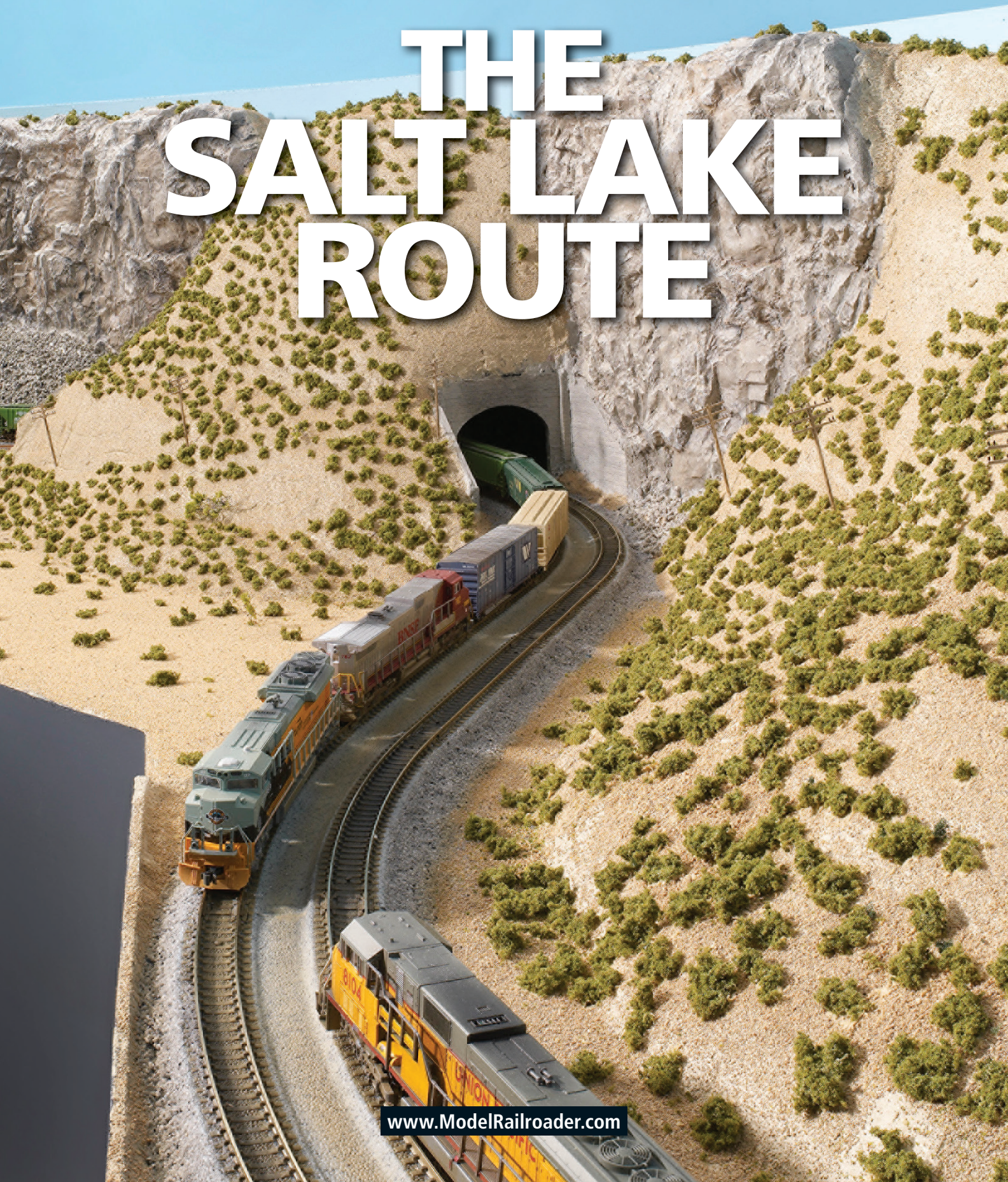


# THE SALT LAKE ROUTE



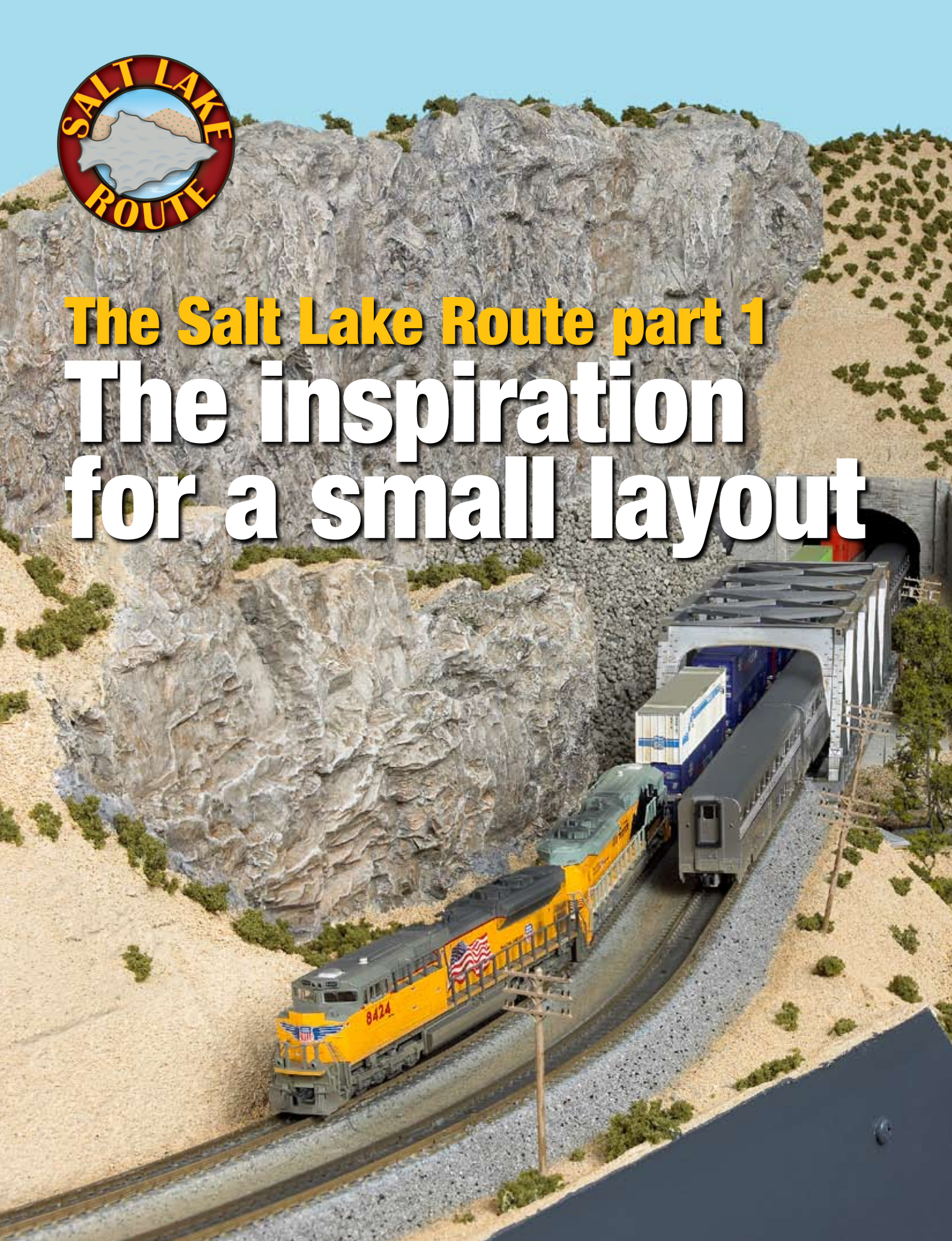




# The Salt Lake Route part 1

# The inspiration

# for a small layout







1. The rugged mountain desert scenery of the Meadow Valley Wash provides a picturesque backdrop for trains on the N scale Union Pacific Salt Lake Route. The 4 x 9-foot model railroad, built by retired managing editor Dick Christianson, features Kato Unitrack with super-elevated curves.

## Our portable 4 x 9-foot N scale project layout starts with two photos

By Dick Christianson

Photos by Jim Forbes and Bill Zuback

**M**y wife and I had just returned from a trip to Norway to see the homeland of my ancestors and renew the acquaintance of a couple of Norwegian model railroading friends. After 28 years of work at Kalmbach Publishing Co. as – at various times – *Model Railroader's* copy editor and managing editor, editor of *Classic Toy Trains*, and editor-in-chief of Kalmbach Books, the Norway trip was a post-retirement treat Diana and I had planned for several years. But now we were back home and had both slipped into retirement pretty comfortably. Then the phone rang.

*Model Railroader's* managing editor, David Popp, and editor, Neil Besouglhoff, made a proposal. They wondered if I'd be interested in building an N scale project railroad for the magazine. The parameters were broad, the deadlines reasonable, and the compensation was within the guidelines of what one on Social Security can receive. So after consulting with Diana, I agreed.

Here was the guidance I got from MR: The N scale layout needed to feature modern-era Western railroading, preferably feature Digital Command Control (DCC), and use Kato's new Unitrack with super-elevated curves. It also had to be portable, roughly 4 x 8 feet, and be aimed at those in the beginner-to-intermediate skill level.

Most of these criteria left me little wiggle room: N scale (standard gauge), DCC (brand left up to me), Kato's super-elevated curved track (thus main-line railroading), portable (lightweight materials), and skill level (I consider my skills intermediate, at best). There were two elements that would require more thought and decision-making.

### Modern era in the West

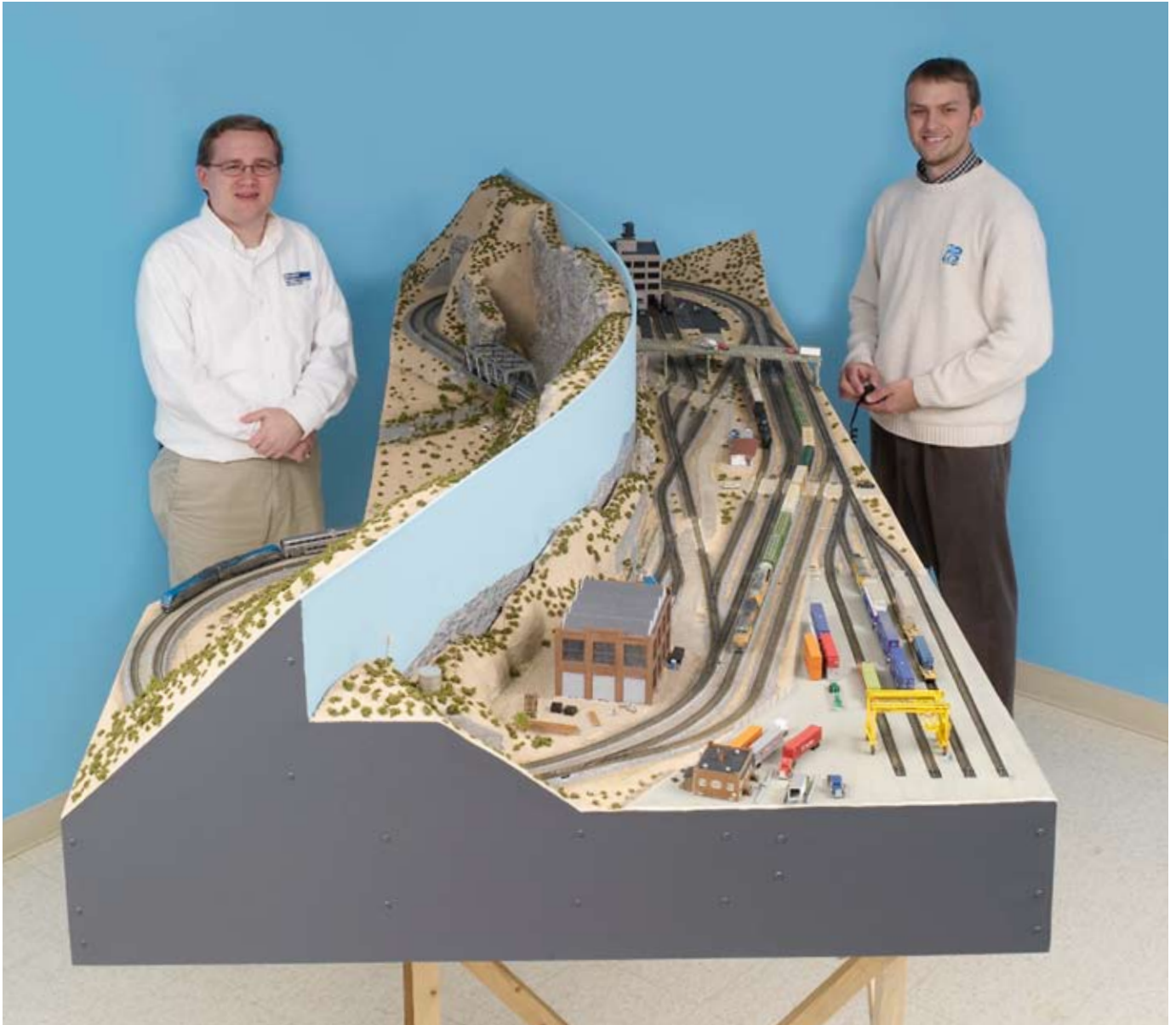
I suppose I could have chosen one of the smaller regional lines, but wanting

#### ▶▶ Union Pacific Salt Lake Route

**Coming next month:**

Building the roll-away benchwork





2. *Model Railroader* associate editor Cody Grivno and graphic designer Drew Halverson operating the Salt Lake Route.



3. A BNSF Ry. detour train passes under the Nevada state highway 317 bridge in Caliente, Nev.

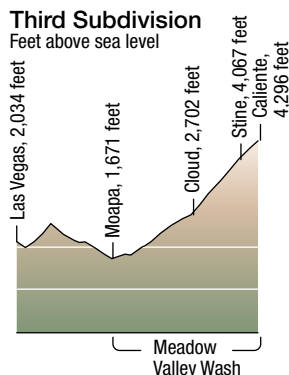
## South Central District

of the Union Pacific

0 Scale 200 miles



— BNSF Ry. trackage rights  
— Third Subdivision (Las Vegas - Caliente, Nev.)

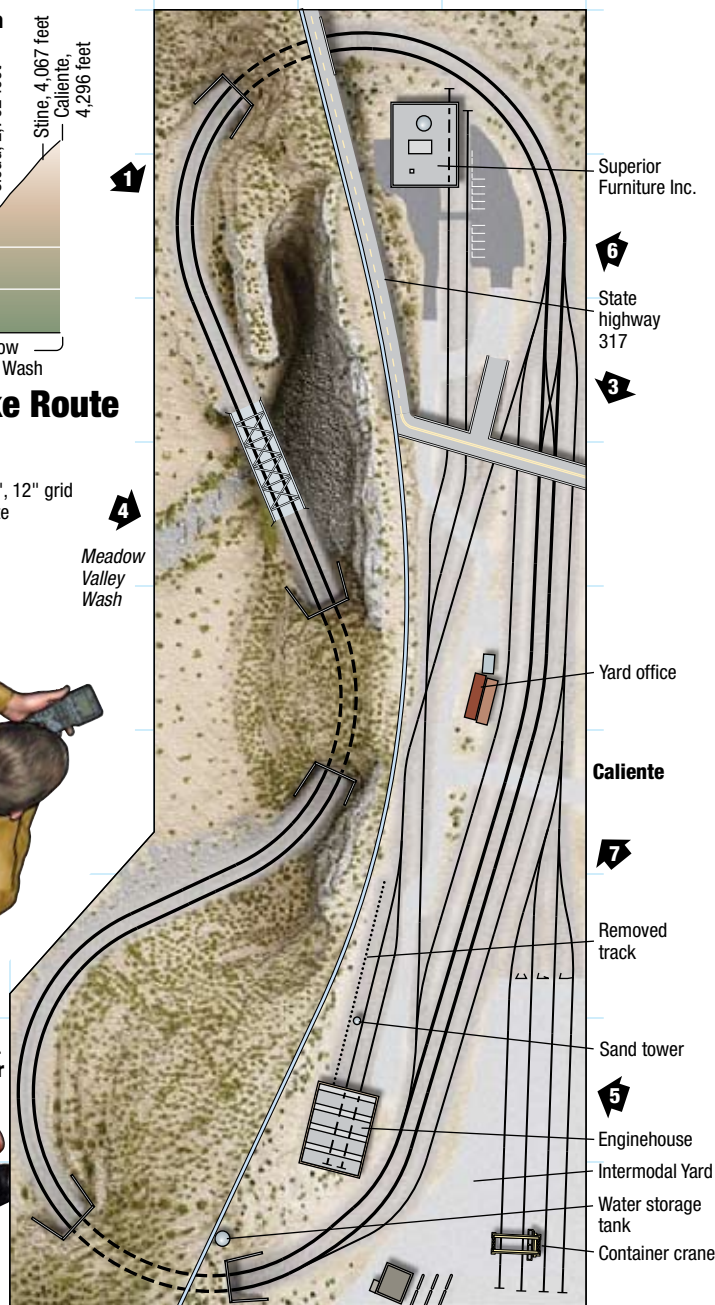


## The Salt Lake Route

N scale (1:160)  
Layout size: 4 x 9 feet  
Scale of plan: 3/4" = 1'-0", 12" grid  
Numbered arrows indicate photo locations

### ▶▶ The layout at a glance

**Name:** The Salt Lake Route  
**Scale:** N (1:160)  
**Size:** 4 x 9 feet  
**Prototype:** Union Pacific  
**Locale:** Meadow Valley Wash in southern Nevada  
**Era:** present day  
**Style:** island  
**Mainline run:** 15 feet  
**Minimum radius:** 10"  
**Minimum turnout:** no. 6  
**Maximum grade:** level  
**Benchwork:** L-girder  
**Height:** 50"  
**Roadbed:** molded styrene on cork  
**Track:** Kato Unitrack  
**Scenery:** Sculptamold over extruded-foam insulation board  
**Backdrop:** 1/8" tempered hardboard  
**Control:** Digitrax Digital Command Control



Illustrations by Rick Johnson

to stick with mostly ready-to-run equipment, that meant BNSF Ry. or Union Pacific. Burlington Northern took over the Santa Fe (one of my favorite railroads, and I bear a bit of a grudge), so I zeroed in on the UP.

But where along the UP? Wyoming, though a beautiful state, really doesn't offer a lot of dramatic scenery. Northern Utah and northern California? Maybe, though the Feather River Canyon has certainly been modeled many times before. Southern California? Mojave Desert, Sullivan's Curve, Cajon Pass – also pretty well represented by layouts in all scales.

In the back of my mind, I recalled John Signor's book, *The Los Angeles and Salt Lake Railroad Company: Union*

*Pacific's Historic Salt Lake Route*. Originally published in 1977, by 2008 it no longer covered the modern era (and most, if not all, of the photos were black and white).

During a conversation with Matt VanHatten, senior editor at *Trains* magazine, he asked if I'd seen Mark Hemphill's well illustrated and comprehensive book, *Union Pacific Salt Lake Route* (Boston Mills Press, 1995).

It was exactly what I needed. Beautiful color photographs taken along the entire line from Los Angeles to Salt Lake City; a well-written and detailed description of the line; and maps that include elevations, grades, and mileposts. The text describes in detail the history of the line from its

inception in 1900 as the San Pedro, Los Angeles & Salt Lake RR (soon dropping the San Pedro and becoming the LA&SL) to its publication-date status as the South Central District of the UP (the "Salt Lake Route").

### Rugged mountain desert scenery

Salt Lake City is 784 miles (via the UP) from Los Angeles, and the layout MR wanted was to be roughly 4 x 8 feet. So, which scale half-mile should I build? For several hours I paged through the book, front to back and back to front. There was plenty to choose from. I envisioned the layout would in some way be divided into parts, probably by a backdrop down the middle, so that meant two scenes.





The sheer rock cliffs west of Stine, Nev., provide a dramatic backdrop for a Union Pacific GP30 and two U50Cs climbing the 1.5 percent grade along the Meadow Valley Wash in October 1972. This photo provided the inspiration for half of the Meadow Valley Wash side of the layout. Note the riverbed with gray rock, bushes and trees, and how the Meadow Valley Creek disappears from view behind a rock outcropping. Keith Ardinger photo



Sand, rock, bushes, and tunnel portals were about all the scenery Dick needed to complete the Meadow Valley Wash side of the layout. Pretty simple, except there are a lot of bushes! This photo, taken in March 1992, captured Union Pacific freight NPLAF-15 (North Platte, Neb.-Los Angeles), a unit vehicle train, passing through tunnels 7 and 8 east of Stine, Nev. Dick modeled this scene along with the one west of Stine, shown above. Jamie Schmid photo

One should probably represent either desert or mountain scenery (maybe both); the other should be somewhat more urban, including an industry or two for switching and a yard of some sort – an intermodal yard would be interesting and appropriate.

At this point two photos on facing pages of the Salt Lake book caught my attention. The first (top), by Keith

Ardinger, shows a UP extra struggling up the 1.5-percent grade west of Stine, Nev. The other photo (bottom), by Jamie Schmid, features a pair of big UP locomotives hauling a long string of auto racks through tunnels 7 and 8 east of Stine. The scenery is quite different even though the two photos were taken only a few miles apart. Keith's picture includes a small stream, known as

Meadow Valley Wash, in the foreground. The stream leads your eye into the photo where the train crosses silver steel truss bridges over the stream. To the left the track disappears between sheer, rocky canyon walls. Very dramatic. Perfect for an N scale layout.

Jamie's photo also includes the wash, running parallel to the main line, which cuts through the base of two smallish hills. The tunnel portals aren't far apart, allowing a long train to be in two tunnels at one time. And the scenery appeared to be easy to model: sand, some rock outcroppings, tunnel portals, and small shrubs – millions of small shrubs!

While poring over the photos, I realized that if I carefully rolled the two facing pages together, the two photos became one. Amazingly, I'd found the subject of one side of the layout on facing pages in a book.

## Caliente industrial area

I hoped that I could find similar inspiration in other photos for the Caliente, Nev., side of the layout. No such luck. Elements of several photos provided inspiration, but nothing like the mountain photos. That being the case, I let available structure kits determine what would appear on the other side. One key element would be the intermodal yard; for that, I'd need a Walthers Mi-Jack Translift intermodal crane kit (933-3222) and some sort of office for the yard.

Engine servicing ought to be available also. The Walthers car shop (933-3228) is good-sized, has an interesting roofline, and looked like it would be easy and fun to build. Most of us have more locomotives than we have main line, so this would also be a good spot to store a couple extra engines. A sanding tower would add interest and be appropriate for mountain railroading.

At the other end on the layout, I needed an industry or two. The Walthers Hardwood Furniture Factory kit (933-3232) has covered loading docks – an interesting feature. Another possible industry to include would be the Walthers Interstate Fuel & Oil (933-3200).

Finally, a small, modern yard office along the main line wouldn't look out of place. With that somewhere near the middle of the layout, the space would be pretty well filled.

As far as track goes, the mountain side would make use of the Kato Uni-track with superelevated curves in an S configuration, with a couple straight sections here and there. On the real line through the narrow canyons, most of the right-of-way is single-track



(though many of the tunnels had at one point been modified to accommodate two tracks). I suspended disbelief on the basis of modeler's license. Besides, a double-track main line would allow the MR staff to run trains in circles in opposite directions for display at train shows and other events.

Track configuration on the Caliente side was more problematic, but I'll get into that later in this series. Essentially, though, I needed at least part of an intermodal yard, an engine-servicing area, passing sidings, and a few industries served by rail.

I was given the option of using flex-track on the yard side to join the ends of the Kato section from the mountain side. However, I liked the ease of using the Kato Unitrack with its attached roadbed, so I worked with it throughout. Determining which sections to use proved to be a challenge, but in the end all of the track snapped together perfectly, and the trains run reliably. I believe I chose wisely.

### Perfect railroad for the hobby

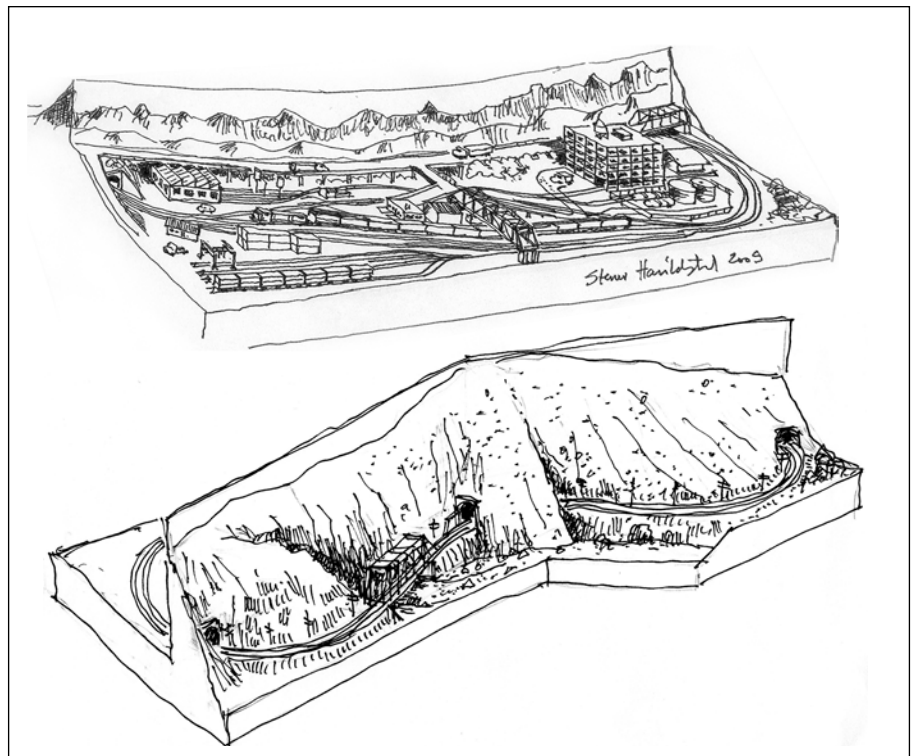
The Third Subdivision of the South Central District runs from Moapa, Nev., at milepost 383.1 and an elevation of 1,663 feet above sea level, to Crestline, Nev., at milepost 495.7 and 5,902 feet [See map on page 39. – *Ed.*] So, in 110 miles the line climbs 4,239 feet. The grade between those two points varies between 1.00 and 2.06 percent. Over that same stretch the line passes through 15 tunnels and weaves back and forth across Meadow Valley Creek on a couple dozen steel bridges. The curves are many, and they're tight. It's a railroad built for modeling!

From Moapa to Caliente, the railroad climbs eastbound through the area known as Meadow Valley Wash. The rest of the trip to the summit at Crestline follows Clover Creek Canyon. Stine, near the locations represented on the mountain side of the layout, is at 4,049 feet.

Meadow Valley Wash is generally dry, though occasional heavy rains can catch the unsuspecting railfan mid-stream. The line today is several feet higher in most places than it was in 1910 when a flood wiped out much of the railroad, carrying ties into the Colorado River and burying rails under as much as nine feet of silt. At considerable expense, the Los Angeles & Salt Lake realigned track, bored new tunnels, and raised the line along the sides of canyon walls to where it is today. In some places the location of the old roadbed is still visible – obviously much too close to the level of the creek!



4. As the maintenance-of-way crew gathers its supplies, Union Pacific no. 1989, painted in the Denver & Rio Grande Western heritage scheme, emerges from a tunnel. Dick modeled the Meadow Valley Wash during its dry season, however you could add water to the creek with a small amount of clear resin.



Stener Harilstadt, Dick's friend from Norway, made these concept drawings of the N scale Union Pacific Salt Lake Route. Though Dick modeled Meadow Valley Wash as drawn, he made some modifications to the Caliente side.





5. The layout is divided down the middle by a 1/8" hardboard backdrop. The Caliente scene includes a furniture factory, yard office, enginehouse, and intermodal yard. Here, Union Pacific GP15-1 no. 1660 switches well cars.



6. With inbound raw material and outbound finished product, Superior Furniture Inc. generates plenty of traffic. It looks like the owner of the Impala has some explaining to do after driving through the freshly painted parking stripes.

## Rail traffic through the Wash

Over the years, rail traffic has been what you'd typically expect: produce and livestock from California headed east, strings of tank cars from the California oil fields, auto racks from the Midwest bound for the West Coast for sale or export, and piggyback trains in both directions. Some of Union Pacific's signature name trains, including *City of St. Louis*, *Challenger*, *City of Los Angeles*, and *Pacific Limited*, also plied these rails.

Today, no passenger trains growl through the canyons, though you could certainly make up a story that would permit Amtrak to run to Los Angeles via Salt Lake City and Las Vegas and vice versa. In terms of freight traffic, though, the first thing you'll notice is that it takes a lot of locomotives to manage these grades. The UP runs long trains over the mountains, and it takes an enormous amount of horsepower to get the freight out of the desert and onto the gentle grades of the Great Plains.

Rolling along behind those six-axle Armour Yellow locomotives today are loads typical of big-time mainline railroading: coil steel cars; a variety of covered hoppers filled with grain, fertilizer, soda ash, and cement; loads of coking coal; and lumber from the Pacific Northwest. Unit coal trains for export to Asia and container trains from the Port of Los Angeles heading east are by far the most common types of traffic seen on the Salt Lake Route.





7. A westbound Union Pacific freight passes an eastbound Amtrak passenger train at Caliente. In the background, UP no. 1660 pushes two cars of raw materials to Superior Furniture Inc.

## Layout preview

This isn't an especially difficult layout to build. It's small enough that it won't take you forever to finish it; the Caliente side of the track plan could be simplified, though as it is, it's not too complex; wiring for Digital Command Control is about as easy as it gets; and the scenery is simple – sand, some rockwork, and bushes (did I mention that there are lots of bushes?). That's about it.

Over the years, traffic has varied enough that almost any cars or locomotives would be appropriate. And if you don't care for the Union Pacific, freelance it and make it your own favorite railroad.

As for operation, the main line is simply two loops with a crossover at one end of the yard. You could run trains east and west in continuous loops while you switch a container train. You could also have a locomotive make up a cut of cars leaving the furniture factory (or bringing in raw materials). If you wanted to, you could run a helper operation out of the engine-servicing tracks, pushing a train up the canyon at one end and then cutting off and returning to the engine tracks when the train comes back around from the other end.

On the mountain side, because of the steep grades, trains headed eastbound work hard and grind along at minimum speeds. Though the model railroad as shown here is level, you can

suggest that eastbound trains are working hard by running them slowly. Trains headed in the opposite direction (westbound and downgrade) could run somewhat faster, suggesting an easier trip, but they'd still be using dynamic brakes on the downgrade. Because of the tight curves, you'd hear flanges squealing – fun to simulate if your modern diesel locomotive is sound-equipped with that feature.

## The railroad step by step

Part of my agreement with *Model Railroader* was that I would photograph construction of the layout. In fact, I shot more than 600 photos. The subsequent articles won't include all of them, but there will be plenty of photos so you can get a clear idea of the process.

If the modern Union Pacific Salt Lake Route doesn't inspire you, the layout could easily be backdated to the steam-to-diesel transition era. You could turn the intermodal yard into a set of team tracks or add a freight house. Hopefully you'll follow along and apply some of what you learn to a model railroad of your own choice. **MR**

### Now on ModelRailroader.com

Read Dick's log book entries as he built the layout over a 10-month period, and watch him give you a tour of The Salt Lake Route on our Web site, [www.ModelRailroader.com](http://www.ModelRailroader.com).



## Meet Dick Christianson

Dick Christianson's name may be familiar to those of you who read magazine mastheads. He became an employee of Kalmbach Publishing Co. in 1978 when he joined the MR staff as copy editor. He later served as managing editor of MR, then was the founding editor of MR's sister magazine, *Classic Toy Trains*. After 7 years in that position, Dick next served – for 10 years – as the Editor-in-Chief of Kalmbach Books. In 2005 he returned to the MR staff as managing editor and, in the fall of 2007, retired after 28 years with the company.

Dick has been married to Diana for 43 years, has two grown daughters, two sons-in-law, and three grandchildren. None of them are model railroaders – yet.





## The Salt Lake Route part 2

# Benchwork with folding legs

How to make portable L-girder benchwork

By Dick Christianson • Photos by the author

**A**s I noted last month, in May 2008, my wife, Diana, and I took a post-retirement trip to Norway. We'd long wanted to visit the beautiful home of my ancestors, and the trip gave us the opportunity to renew our acquaintanceship with some Norwegian model railroading friends. Stener Harildstad was

our host, chauffeur, and tour guide. We had first met him in 1984 when he attended *Model Railroader's* 50th anniversary celebration in Milwaukee; he stayed with us then and has visited us on several other occasions. Stener models the Atchison, Topeka & Santa Fe and Union Pacific over Cajon Pass in N scale.

Not too long after we returned home, I got the call from *Model Railroader* magazine with the N scale layout proposal. Soon after that, I mentioned the project to Stener via e-mail. I noted that if he came to visit in the fall, he'd be welcome to help me build the layout; we set up a visit for early November.

Stener Harildstad holds one end of the N scale Salt Lake Route with the legs folded up inside the L girders. This month, learn how to build easy-to-transport benchwork with folding legs for our 4 x 9-foot project layout.

I did a lot of doodling and planning. I used Kato's track template, but the scale is small, so the resulting plans weren't particularly accurate. In dealing with sectional track (Lionel, Atlas, and others), I've found that templates have their limitations. Nothing beats having sections of track you can lay down on plywood. Eventually, though, I came up with a pretty good sense of what the layout would look like.

### General shape of the layout

I started out with a box of Kato's new N scale superelevated track, set V11, on a piece of 4 x 8 plywood on the

### ▶▶ Union Pacific Salt Lake Route

January 2010: Design  
Coming next month: Track



floor. The basic curve diameter of the outside track (to the outside edge of the molded ballast) is approximately 3 feet. That left almost a foot of unused plywood along most of one side. It occurred to me that I might be able to cut off at least 4 feet of that edge and add it to the other end, extending the layout to 9 feet in length.

I knew that I wanted a through-truss bridge at some point, so I laid down a couple sections of straight track coming out of the curve at the left end. At the end of that I put in a curve heading back toward the right. A couple more short sections of straight track followed by a left-hand curve brought the track close to the 4-foot edge and 9-foot length at the other end.

Unable to wait for legs and L girders and all other preliminary materials, I took one of Kato's three-unit articulated well cars out of its box and put it on the track. In my mind's eye, I was beginning to see Meadow Valley Wash in N scale.

What came next is definitely not a *Model Railroader* recommended practice. Without a detailed track plan, I took a leap of faith and declared the impromptu plan "good enough."

What? Only half the plan is done! The easy half! Are you crazy?

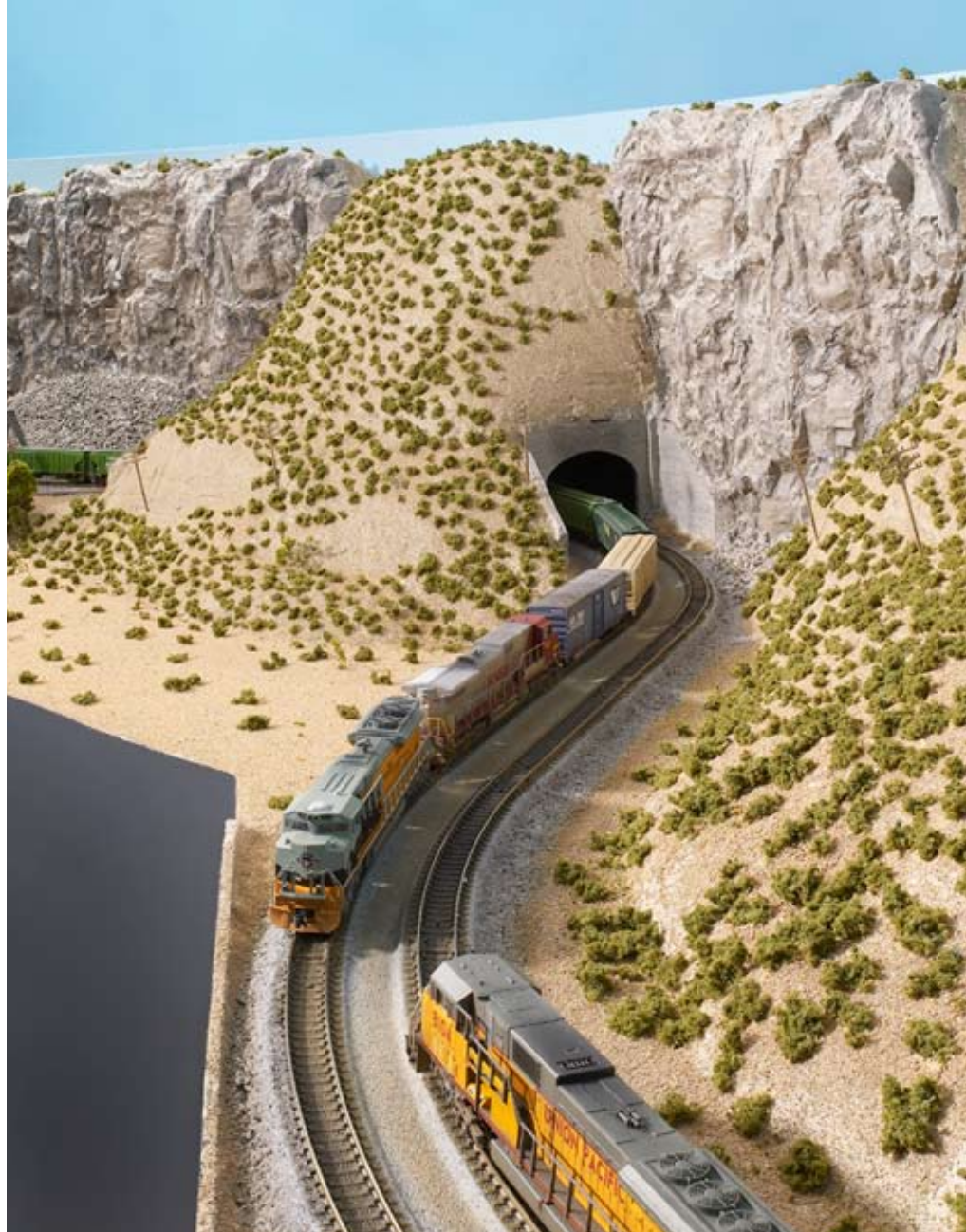
Maybe, but I figured there had to be – at least I hoped there would be – a way to fit an intermodal yard, passing sidings, industrial spurs, and locomotive service tracks on the other side. Talk about a leap of faith!

## Norski to the rescue

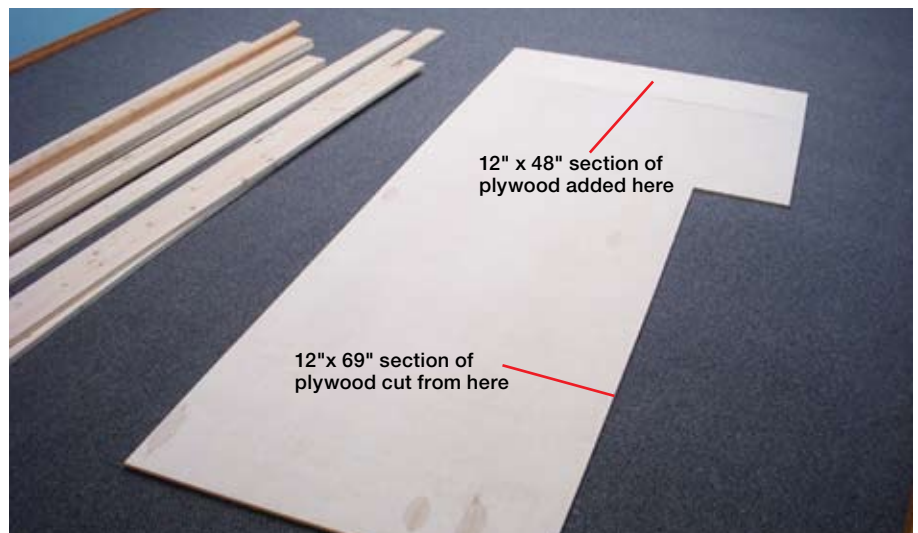
Lest you think I'm a really bad host, we didn't work on the layout night and day. I did show Stener around. We toured Eau Claire, Wis. (my boyhood hometown), visited the twin ports of Duluth, Minn., and Superior, Wis., and stopped in Milwaukee to catch up with the MR staff and see the layouts.

In truth, however, we did spend a lot of time building benchwork. And I'm very grateful to have had Stener helping. Not only were his talents and ideas helpful, it's just good to have companionship while you're working.

Our first step was to position the Meadow Valley Wash track on the  $\frac{3}{8}$ " plywood, using that to figure out where to cut the 12" length of plywood – 5'-9" gave us enough room for the final curve. When we turned that cut-off plywood 90 degrees, placed it at the wide end of the layout, and cut it off at 4 feet, as shown in **fig. 1**, we had 21" of plywood left over (part of which I used later for the 7" x 11" control panel drawer). Now it was time to focus on the benchwork.



A pair of Union Pacific freights meet on the Meadow Valley Wash side of the layout. Dick's impromptu track plan started here. Bill Zuback photo

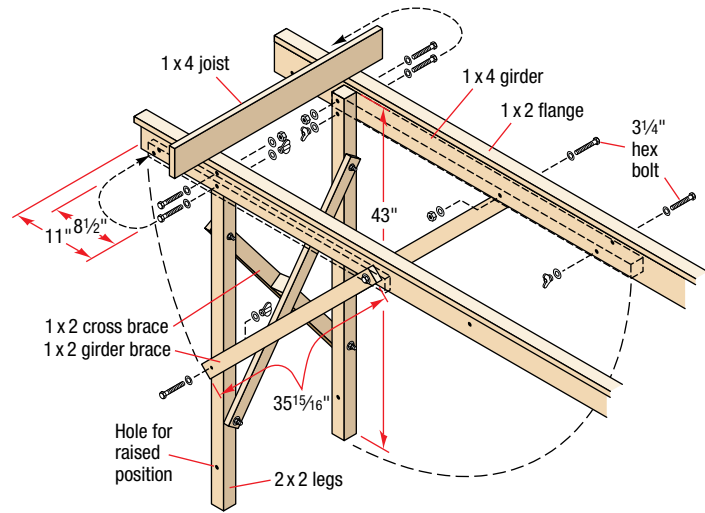


**Fig. 1** A 4 x 8 no more. Dick cut a strip out of the length of the plywood, turned it 90 degrees, and put it at the far end to make a tabletop 9 feet long.





**Fig. 2 Adding legs.** The legs need to be absolutely perpendicular to the L girders for the layout to be stable. Here Stener is using a square to check the position of the legs.



**Fig. 3 Folding benchwork.** This illustration shows how Dick incorporated the folding legs into the L-girder benchwork. Having the legs tuck inside the girders makes the N scale layout easier to transport. Illustration by Rick Johnson



**Fig. 4 Reinforcing the ends.** Dick and Stener realized that the layout would be lifted at the ends, and that the fascia would extend to the bottom of the girders. They added 1 x 4s at each end of the layout to serve as gripping points.



**Fig. 5 Keep that layout rollin'.** Managing editor David Popp encouraged Dick to put the layout on casters. The wheels make it easier to rotate the layout for scenery work or photos.

## L-girder benchwork

L-girder benchwork is ideal for railroads with grades. There are no grades on this layout, and only Meadow Valley Wash would be below grade. However, one of the other advantages of L-girder benchwork is that it provides plenty of strength using a minimum amount of wood. One of my requirements was that the layout needed to be portable, and anything I could do to keep the weight down would be a good thing.

Rather than go into nut-and-bolt detail about L girders here, I recommend that you get a copy of Jeff Wilson's *Basic Model Railroad Benchwork* (Kalm-bach Publishing Co., 2002).

Step one is to build two L girders. We used 10-foot lengths of 1 x 4, with a 10-foot 1 x 2 for the flange. [A 1 x 3 is even better for a flange. – Ed.] We glued

and nailed the two girders, rather than screwing them together.

Each of the four legs is a 43"-long 2 x 2. I'm really happy with the resulting 50" height of the layout (leg length, plus nominal 4" stringers, plus 3/8" plywood, and casters). I'm about 5'-10" tall, and I found it to be a very comfortable height to work on, wire under, and watch trains pass by.

It's important when you attach the legs to the L-girder that they're square to the girder. See **fig. 2**. We used two 3 1/4"-long carriage bolts to attach each of the legs to the girders. Girder braces (1 x 2) attached with the leg square to the girder help keep the layout from swaying from end to end. Cross braces (1 x 2) keep the benchwork from swaying side to side, as shown in **fig. 3**. The girders are inset 4" from each side of the plywood at the

3-foot end and run parallel the length of the layout.

## Folding legs

The layout needed to be portable and, when completed, it needed to fit through a roughly 4-foot-wide door and rest in a 10-foot-long space (the back of the Kalm-bach van). Stener, being an architect, is very handy with a pencil and rule. Together we figured out how the legs of the layout could be made so that they would fold up inside the benchwork.

There are eight bolts on the layout attached with wing nuts. We began at one end, removing the two wing nuts at the bottoms of the legs and pulling out the bolts. This allows the length-wise angle braces to hang down. Then, with the same end supported (a person can hold it), we loosened the wing nuts



at the tops of both legs and pulled out the bolts. With this end still supported, we swung the leg assembly up inside the girders and put the bolts from the top of the leg through holes drilled in the girders and the legs expressly for that purpose. Next, we swung the girder braces up and put the bolts through holes in the girders drilled to match the girder-brace holes in the legs. See **fig. 3**.

We followed the same procedure at the other end, and the layout was ready to move. We eventually made one modification to standard L-girder construction for the sake of portability. We added a length of 1 x 4 flush across each end between the girders and below the joists to serve as lifting points. See **fig. 4** on the opposite page.

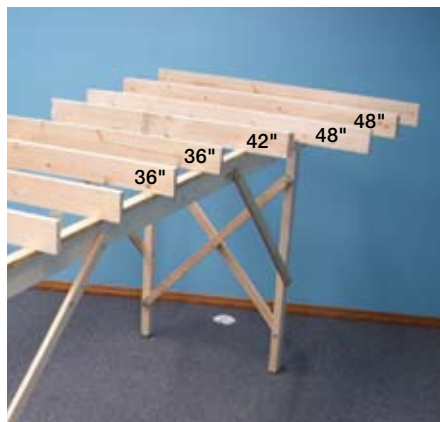
One of the best suggestions that MR's managing editor David Popp gave me was to put casters on each leg, as seen in **fig. 5**. I'd already put in leveling bolts, but I followed his advice. The casters raised the layout another inch or so, but it made moving the layout much more convenient. I could whirl it around whenever I wanted to get a better angle, better light, or better position for photographs.

With the leg-and-girder assembly put together, we cut the joists and screwed them into the girder flanges. The 1 x 4s are the width of the plywood to which they will be attached, as shown in **fig. 6**. We doubled the joist under the plywood splice at the wide end so that both edges would have a firm support. See **fig. 7**.

After we had the benchwork built, Stener asked the logical, but previously unasked, question, "Can we get it out of the basement?" For one horrible moment I was sure we couldn't. But then I realized that we'd simply need to tip it on one edge, carefully make an S curve through the workshop, and then guide it through the sliding glass door of my walk-out basement. From there we'd just turn it right-side-up, carry it around to the front yard, and put it in the van.

## Meadow Valley Wash bed

With the plywood sheet resting on the joists, Stener and I marked on the plywood where the track would be, where the wash at the end of the canyon would be, and where the creek would disappear between the canyon walls. Then we used a saber saw to cut out the base for the creek as shown in **fig. 8**. Next, Stener measured down 2" from the tops of each of the appropriate joists and cut them with a saber saw. See **fig. 9** at right. After adding a couple of supports here and there, we placed the plywood creek on the now-slimmer joists, as seen in **fig. 10** on page 44.



**Fig. 6 Cutting to fit.** Dick and Stener cut the joists to fit the curve of the layout on the Meadow Valley Wash side; the other side is straight. The joists at the near end are 3 feet long; at the far end they're 4 feet. The fourth one in from the far end is about 42".



**Fig. 7 Double the joist.** Where the additional 12" of plywood was added to the end of the layout, another joist was needed for support. It's the same length as its mate, and Dick and Stener secured it with glue and screws to the L girder.



**Fig. 8 Cookie-cutter benchwork.** Meadow Valley Creek runs out from between a pair of canyon walls, flows beneath a through-truss bridge, and then spreads out (in flood times) into a wide wash. Stener marked this on the plywood and then cut it out, saving the cut piece for the floor of the wash.

With the plywood in place, we drew pencil lines across the plywood directly over each joist. As shown in **fig. 11**, we then drove 1" drywall screws through the plywood into the joists.

## Fancy fascia

Fascia, the flat edge trim attached to the side of most model railroads, is a beautiful thing. In addition to providing a place to attach bill boxes, town names, cup holders, and plug panels for walkaround control, fascia finishes a layout. The fascia has to be firmly mounted. Stener and I cut 7" lengths of 1 x 2 and screwed them into the sides of each of the joists. See **fig. 12**.

The fascia itself is 1/8"-thick tempered hardboard. We cut three 8 1/4"-wide lengths 8 feet long for the sides. We'd cut the ends later to roughly match the shape of the terrain. We used

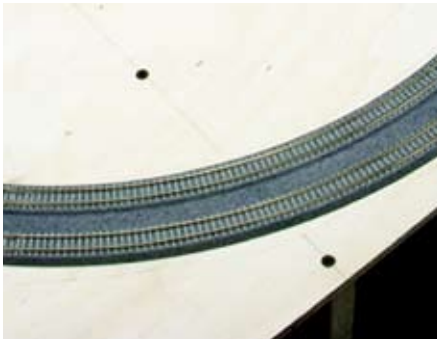


**Fig. 9 Lowering the joists.** After marking the edge of the creek bed and wash on the joists, Stener measured down 2" and then used a saber saw to cut the joists. These slimmer, cut-down joists support the base for the plywood creek.





**Fig. 10 Below-grade scenery.** Here the grade-level plywood has been removed and the wash bed plywood put in place. A few additional supports were needed to keep the plywood from sagging between joists.



**Fig. 11 A sturdy layout.** Dick and Stener used a pencil to mark the location of the joists, applied glue to the tops of the joists, and then drove drywall screws through the plywood into the tops of the joists. At this point all of the joists are tied together by the girders below and the plywood above.



**Fig. 12 Fascia fine points.** Dick and Stener used glue and screws to attach vertical 7" lengths of 1 x 2 to the side of the joists to support the layout's hardboard fascia.



**Fig. 13 A clean look.** Here's the layout with the hardboard fascia attached to the sides. The ends will come later once the scenery contour has been determined. It's amazing how adding the fascia gives the layout a finished look.



**Fig. 14 Backdrop support.** Because the layout's design calls for two different types of terrain, a backdrop down the middle of the layout makes a good scene divider. The 1 x 2s and 2 x 2s are attached to the plywood with metal L-brackets.

$\frac{3}{4}$ "-long Phillips roundhead screws to attach the fascia to the vertical supports previously attached to the joists, allowing about  $\frac{1}{4}$ " of the hardboard to extend above the top of the plywood. Two screws per joist sufficed. I considered using flathead screws that could be countersunk flush with the fascia. They would be less obtrusive, perhaps, but I was concerned that they might pull through the thin hardboard. See **fig. 13**.

### Double-sided curved backdrop

There are a couple of ways to visually divide a layout, and Stener and I chose to run a double-sided, curved backdrop roughly down the center. On the Meadow Valley Wash side, the hills and steep bluffs could have pretty well divided the two sides of the layout by themselves, but I needed to hide the backs of the mountains.

We made the backdrop from tempered hardboard. L-girder benchwork lends itself well to adding a backdrop by allowing you to attach vertical supports to the joists. At this point on our layout, however, the joists were covered by plywood. Had we planned ahead, perhaps we could have cut the plywood in such a way as to allow us to drop supports to the joists, but we didn't.

Instead, we used lengths of 10"-high 1 x 2 attached to the plywood with L-brackets at appropriate locations to support the backdrop. As you can see in **fig. 14**, we beveled the tops of the supports, angling them down toward the Meadow Valley Wash side, making it easier to cover them with scenery. The backdrop itself is attached to the yard side of the vertical supports.

We cut three 1 x 8-foot strips of hardboard for the backdrop. The material we used is smooth only on one side, so we positioned one piece with the smooth side facing the supports. This provides a smooth surface for the couple of inches of sky that would show above the mountains on the Meadow Valley Wash side.

Next, we marked the backdrop to show where each of the supports would be, applied glue to the back of the supports, and then attached the hardboard using flathead screws carefully drawn down flush with the surface, as shown in **fig. 15**. The photo also shows how we cut openings for the tracks to pass between the scenes.

And since the entire backdrop needed to be more than 9 feet long, we ended up splicing another 18" or so at the other end. We used additional supports at the splice point and at both edges of the tunnel openings at both ends.



With one side of the backdrop firmly glued and screwed in place, we applied carpenter's glue on the rough side of another length (having cut matching tunnel openings) and placed it against the backside of the hardboard already in place. See **fig. 16**. Note that we alternated ends for the splice.

We used 1 x 4 scraps, shown in **fig. 17**, clamped at the top and screwed on an angle at the bottom to apply pressure as evenly as we could while the carpenter's glue dried.

Once the glue dried, we removed the clamps. I sanded the joints on both sides of the backdrop and applied spackling compound. When that dried, I sanded the joint and it was ready for paint.

### End fascia

By this time, Stener had sketched our joint vision of how the layout would look. The Meadow Valley Wash side took only one version; it was pretty well set in stone (so to speak). The Caliente side – well, like the track plan, that was still in a state of flux. Nevertheless, we had general ideas of where elements would go and what the slopes at the ends of the layout would look like.

The first step was simply to screw some large hardboard pieces to the ends, lining up the bottom with the bottom of the side fascia and the top with the top of the backdrop. See **fig. 18**. Then we marked the back of the hardboard where we thought the mountains might fall, as shown in **fig. 19**. It would be possible to trim them later to match the actual mountain contour or, as in one corner of the yard, to add more hardboard to match the ground contour, as shown in **fig. 20**.

### Fond farewell

Too soon it was time for Stener to bid farewell to the Salt Lake Route layout and head home to Oslo. I'm sure I could have muddled along and built benchwork on my own, but it was nice to have an extra pair of hands. I've continued to update Stener via e-mail on my progress, and he's done a couple more sketches to more accurately reflect what the yard side looks like. But more on that later. From this point on, I was – for better or worse – pretty much on my own. **MR**



**Fig. 15 Fitting the backdrop.** Even though only a few inches of sky shows above the hills on the Meadow Valley side of the layout, that hardboard surface had to be smooth.



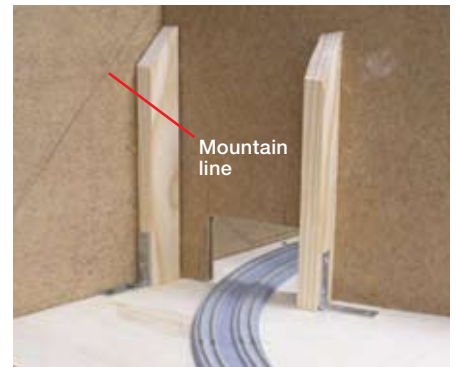
**Fig. 16 Two-sided backdrop.** Since the laminated backdrop couldn't be screwed together, Stener applied a liberal amount of carpenter's wood glue to the mating faces.



**Fig. 17 Squeezed together.** C-clamps at the top of the backdrop and drywall screws at the bottom force the back-to-back pieces (rough side to rough side) of tempered hardboard together until the carpenter's glue dries.



**Fig. 18 More fascia.** Stener attached large hardboard pieces to the ends of the layout with screws.



**Fig. 19 Marking the mountains.** Dick used a pencil to mark where the mountains would meet the fascia.



**Fig. 20 Changing terrain.** When the layout was further along, Dick felt like there needed to be a reason for the tracks to change direction, so he added a hill. The fascia extensions help hide the extruded-foam insulation board.

### Now on ModelRailroader.com

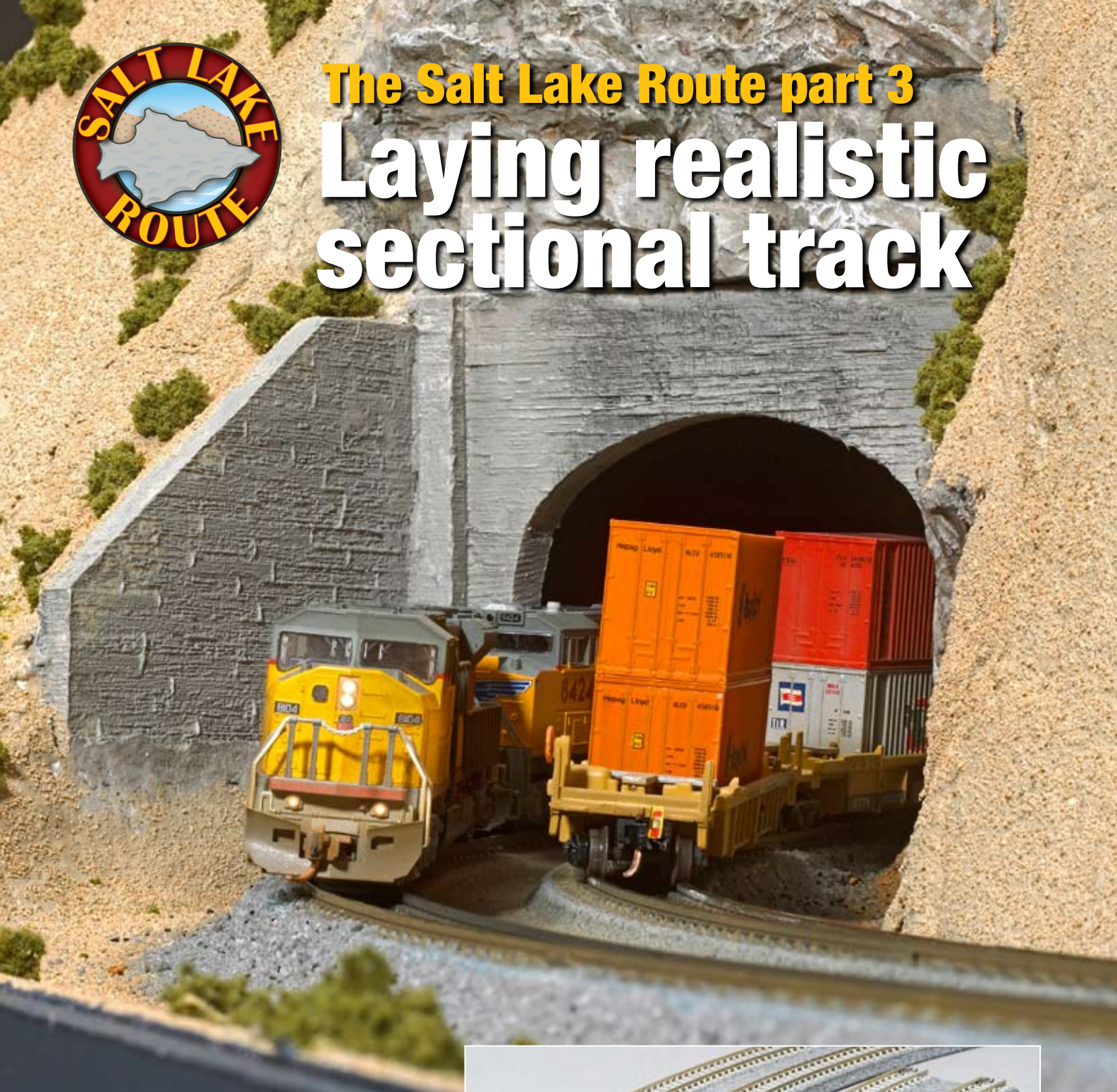
Registered Web site users can read Dick's layout construction log book, and magazine subscribers can take a video tour of the Salt Lake Route online at [www.ModelRailroader.com](http://www.ModelRailroader.com).





## The Salt Lake Route part 3

# Laying realistic sectional track



A pair of Union Pacific freights bank into the superelevated curves on the N scale Salt Lake Route. This month, Dick Christianson explains how he installed Kato Unitrack, including the firm's new double-track sections with superelevated curves (inset), on our project layout.



Kato's reliable and ingenious sectional track make this 4 x 9 N scale track plan possible

By Dick Christianson • Photos by the author



One of the parameters *Model Railroader* gave me regarding the N scale project layout was that I needed to use Kato's new superelevated sectional track (set V11), at least for part of the railroad. What I knew of traditional Kato Unitrack, with its molded roadbed, was positive. The firm's new superelevated double track looks terrific, with molded gray and black ballast. The crossties are gray, representing concrete. Interestingly, the Union Pacific has concrete ties on the grade through Meadow Valley Wash and Clover Creek Canyon, so the track was prototypical for the area modeled.

I'd experimented with the superelevated track on the Meadow Valley Wash side of the layout before I realized that all wasn't as simple as it seemed. I first laid out the track so it went directly from a left-hand curve into a right-hand curve. The track clips fit, but there was a heck of a difference in track levels where the sections, which were elevated on opposite rails, met. Clearly, I was missing some sort of transition sections designed to take curves to level and then to superelevation in the opposite direction.

### Transition sections

Set V11 included half-sections that transition from a left-hand curve directly into a right-hand curve (or vice versa). At the end of each curve I installed the appropriate half-section to keep the track geometry intact.

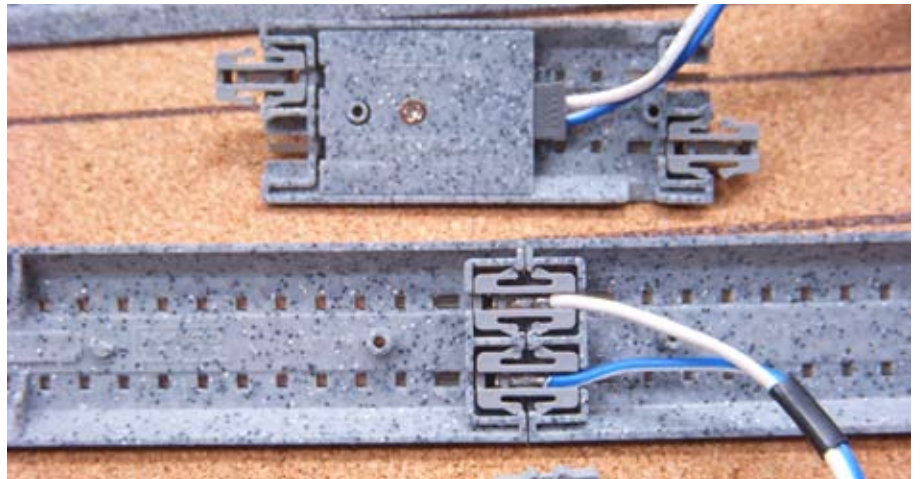
The half-section transition was what I needed to bring the curve at the left end toward the center of the layout, instead of parallel to the edge. It functioned the same way at the other end. With the proper placement of straight sections between the curves, the track fit perfectly along the Meadow Valley Wash side of the layout at both ends.

Those half sections came into play on the yard side as well, determining where the molded double-track sections would end and the single-track straights and curves would begin. It was just a matter of which sections to use. I knew it could be done.

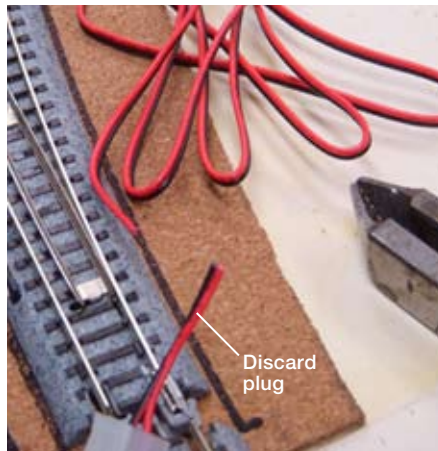
### Cork roadbed too?

I began by tracing along the edges of the roadbed of the track on the Meadow Valley Wash side. Then I cemented N scale cork roadbed along the outsides so that the beveled edge of the cork aligned with the slope of the molded roadbed. I attached two strips of cork down the middle to provide support and a surface to apply Liquid Nails.

You're probably asking, "Why would he add cork roadbed?" I felt the cork



**Fig. 1 Two types of joiners.** There are two ways to attach feeder wires to Kato Unitrack. The first way is with the firm's short track sections (no. 041) that have small sockets built in for the feeder wire plug (top). The second option is to use track clips/rail joiners (no. 24-818) with the feeder wires attached.



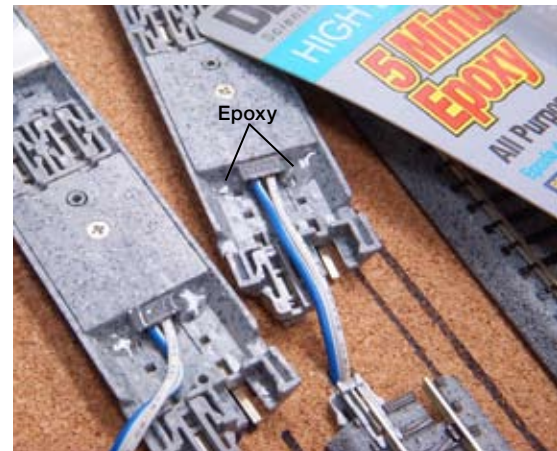
**Fig. 2 Wire modifications.** Kato turnouts use control wires with a plug at one end. Dick removed these plugs so he could slip the wires through holes drilled in the plywood subroadbed. The turnouts operate manually.

would absorb some sound. Molded plastic on plywood didn't seem like a great sound-deadening combination.

### Two kinds of feeders

Kato has two options when it comes to feeder wires, and I used both on the Salt Lake Route. First, Kato offers short track sections with sockets built in under the roadbed for the feeder-wire plug. See **fig. 1**. A miniature plug on one end of the two wires (blue and white) snaps into the socket. A larger plug, part of Kato's plug-and-play direct-current system, is attached to the other end of the wires. Since I used DCC on the layout, I clipped the plug off, as shown in **fig. 2**.

It's important to orient the blue and the white wires the same throughout the layout so the polarity isn't reversed. That way blue is always the same rail, and white is always the other rail.



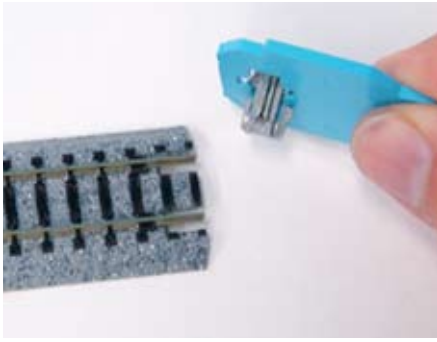
**Fig. 3 A solid bond.** Dick used five-minute epoxy to cement the miniature plug to the Unitrack. This prevents the plug from falling out when the feeder wires are pulled through the holes he drilled in the layout surface.

After connecting the miniature plug to the track, I cemented it with five-minute epoxy. See **fig. 3**. Only after I had glued and nailed down some of these sections was without power. Apparently, as I pulled the wires down through the holes in the plywood beneath them, I must have tugged hard enough to pull the plug from its socket. Fortunately, I tested the connection before I had laid much track. Now the epoxy keeps the plug from pulling out.

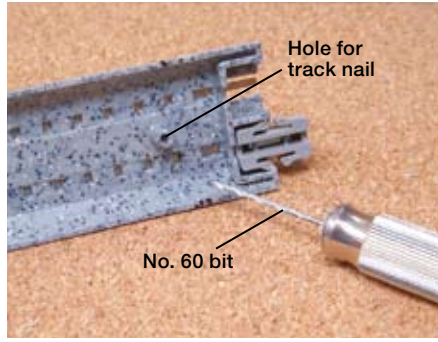
## ►► Union Pacific Salt Lake Route

January 2010: Design  
February 2010: Roll-away  
benchwork  
April 2010: Wiring

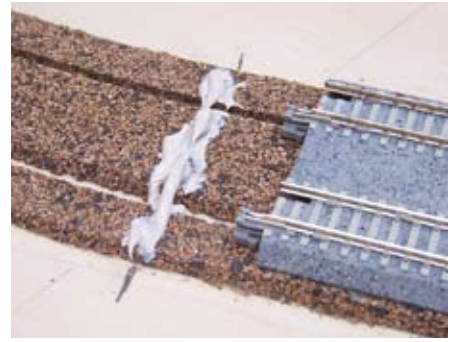




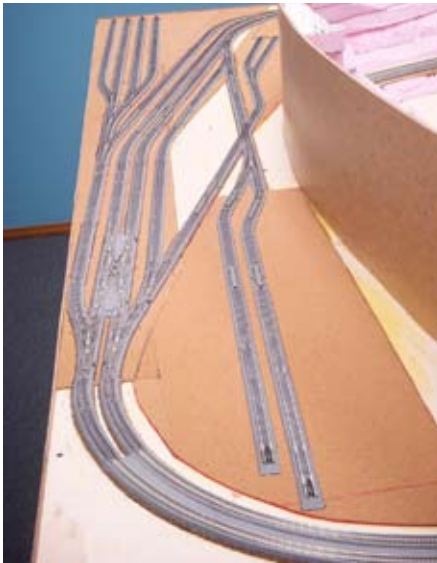
**Fig. 4** Oh, that's what it's for. The blue plastic tool included with Kato Unitrack is for removing the track clip/rail joiner. The tool levers the clip/joiner out of its socket.



**Fig. 5** Hidden holes. From above, it appears the Kato Unitrack doesn't have holes for track nails. Underneath the track are hollow tubes that Dick opened with a no. 60 bit.



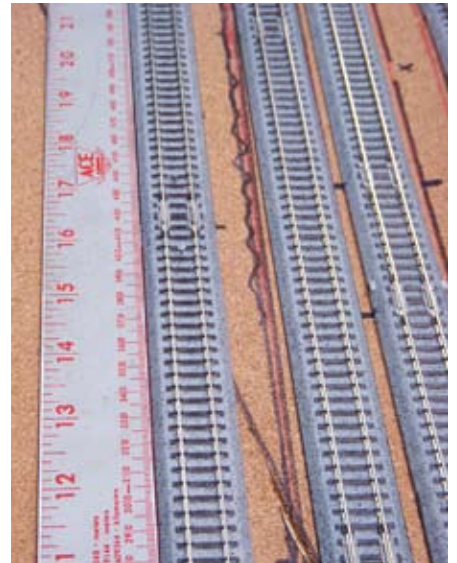
**Fig. 6** Securing the track. To prevent the track from coming loose when moving our portable layout, Dick further secured it to the cork with Liquid Nails for Projects.



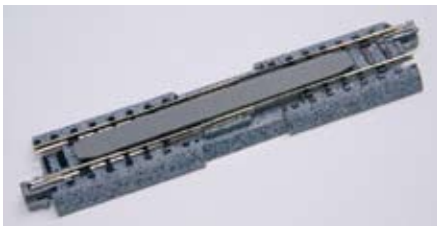
**Fig. 7** Testing the track plan. Dick laid out the Kato Unitrack on the Caliente yard side of the layout. He positioned the track as far away from the backdrop as possible to make room for the enginehouse and furniture factory.



**Fig. 8** Spacing guide. Dick used a notecard to maintain proper track spacing on the layout. The red marks of the main line match up with the super-elevated double track from the Unitrack V11 set.



**Fig. 9** Track alignment. While maintaining the desired spacing between tracks, Dick placed a metal yardstick along the edge of the molded-plastic roadbed to make sure the parallel tracks would be straight as an arrow.



**Fig. 10** Expansion track. These clever 3" lengths of track can be expanded to 4 1/4". The plastic in the middle has molded wood plank detail, allowing the track to double as a grade crossing.

Second, Kato produces combination track clips/rail joiners to which blue and white wires have been attached (soldered to the metal rail joiners). Since the track plan doesn't always call for a short section of track where power is needed, I needed to use a few of these. Kato offers a tool with the joiners for

removing the original clips, shown in **fig. 4**.

To join Kato Unitrack, I slid the rail ends into the joiners of the adjoining section (molded into plastic spring clips that hold the plastic subroadbed sections together) and pushed until I could hear and feel a snap. This system results in a positive mechanical and reliable electrical connection.

To take sections apart, I held one in each hand and with my thumbs, pushed the joint away from me. The clip farther away released first. As I continued pushing on the track, the near clip released. I experimented on the yard for hours with various curve diameters and straight-section lengths. Despite snapping sections together and pushing them apart dozens of times, they continued to hold well and provide a positive electrical connection.

## Nails and Liquid Nails

Kato provides drilling guides that make it easy for you to nail down its track. From the top, no nail holes are visible through the ties. If you flip the track over, however, you'll see hollow tubes, as shown in **fig. 5**. Insert a no. 60 bit (in a pin vise) into the "tube" and give it a couple twists. Now you have a nail hole from above.

I nailed down the track all the way around the layout. I also used Liquid Nails for Projects, sparingly, at rail joints and in the middle of each section. See **fig. 6**.

Before I began this project, MR executive editor Andy Sperandio mentioned that I should pay attention to how the rails meet from section to section. He had observed that sometimes Kato HO track seems to have a slight upward curvature at the ends of each sec-



## Materials List

### Kato Unitrack

- 20-000 9<sup>3</sup>/<sub>4</sub>" straight (22)
- 20-010 7<sup>5</sup>/<sub>16</sub>" straight (13)
- 20-020 4<sup>7</sup>/<sub>8</sub>" straight (7)
- 20-030 2<sup>1</sup>/<sub>2</sub>" straight (6)
- 20-041 2<sup>7</sup>/<sub>16</sub>" straight feeder (7)\*
- 20-048 2" straight with bumping post (6)
- 20-050 3"-4<sup>1</sup>/<sub>4</sub>" expansion section (16)
- 20-101 9<sup>3</sup>/<sub>4</sub>"-radius curve (4)
- 20-110 11"-radius curve (1)
- 20-111 11"-radius curve (2)
- 20-121 12<sup>3</sup>/<sub>8</sub>"-radius curve (1)
- 20-140 15"-radius curve (2)
- 20-150 28<sup>1</sup>/<sub>4</sub>"-radius curve (4)
- 20-160 19"-radius curve (5)
- 20-202 no. 6 left-hand turnout (6)
- 20-203 no. 6 right-hand turnout (6)
- 20-210 12<sup>3</sup>/<sub>4</sub>" double crossover
- 20-300 15-degree crossing
- 20-437 double-track bridge, silver
- 20-8701 V11 track set
- 20-004 (2), 20-023 (1), 20-042 (1), 20-043 (1), 20-181 (7), 20-182R (3), 20-182L (3)

\*Dick used seven of these short feeder sections as indicated on the track plan. In seven other instances, he used Kato factory-wired terminal joiners as feeders. The other two feeders were in section 20-043 from the V11 track set.

### Miscellaneous

- Cork sheet
- Liquid Nails for Projects
- N scale cork roadbed
- N scale track nails

tion, making a peak where the rails meet. I laid the track with this in mind, adjusting the heights of the rail ends by driving the nails a little deeper. I also filed a few joints for smoother transitions. Running your fingernails along the heads of the rail will tell you which joints could stand some filing.

### Turnouts

All of the turnouts are on the Caliente yard side of the layout. I used no. 6s throughout, including the double crossover at the right end of the yard. This section of track (four turnouts molded into one section) provides a way for locomotives to get from one side of the yard to the other. A crossover at both ends would have been ideal, but that would have meant shortening the sidings. Since long unit trains would be common on this model railroad, I

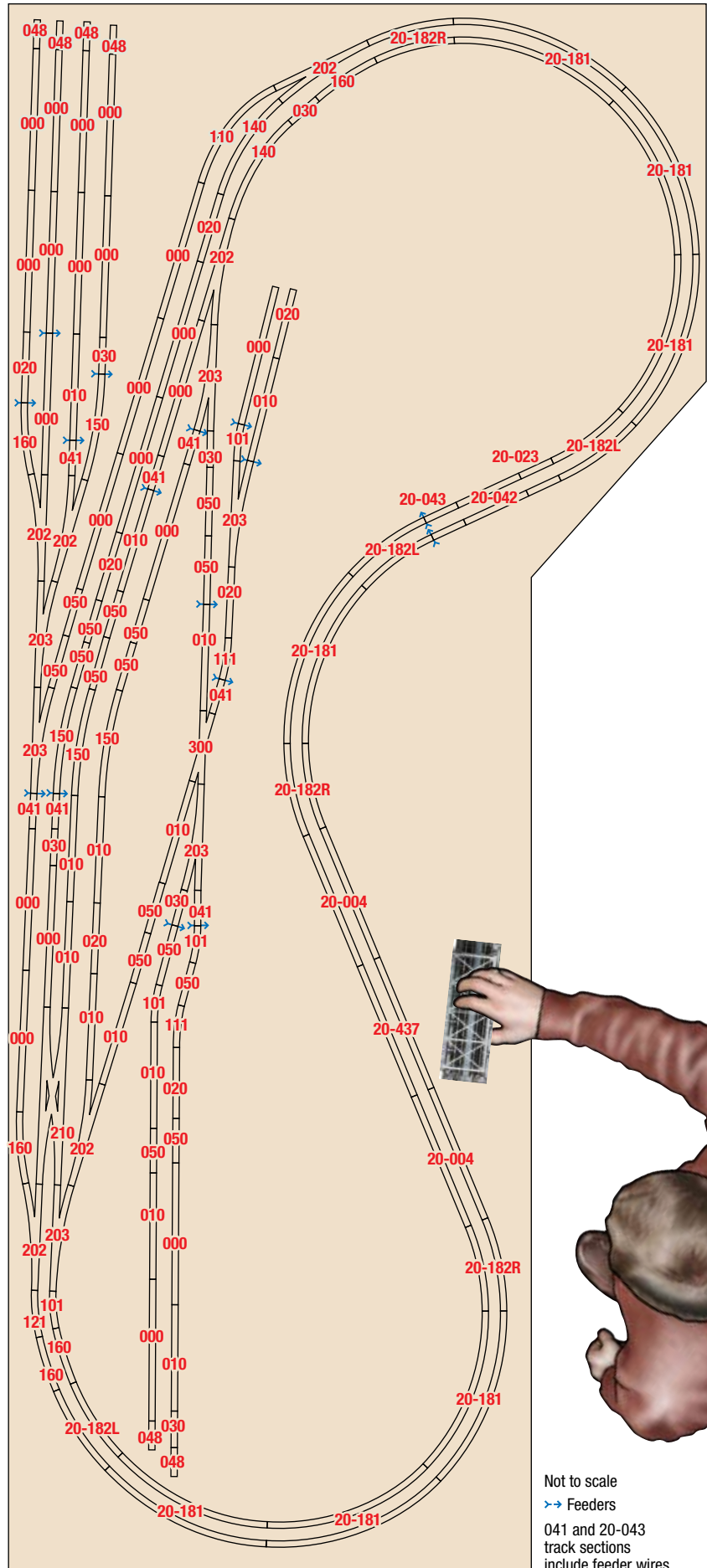


Illustration by Rick Johnson

Not to scale

>>> Feeders

041 and 20-043

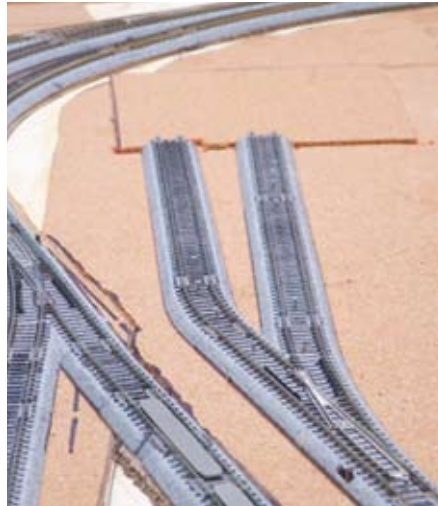
track sections

include feeder wires





**Fig. 11 Bumping posts.** To finish the intermodal yard and industrial sidings, Dick installed 2" track sections with bumping posts. He secured each section to the layout with track nails and Liquid Nails for Projects.



**Fig. 12 Roughing it in.** Since the track spacing for the Walthers enginehouse is different than the geometry of Kato's no. 6 turnout, the tracks aren't parallel. The difference is only visible from the far end of the layout.



**Fig. 13 Quick weathering.** Dick used Floquil's three-pack of organic solvent-based track weathering markers to paint the web of the rail on the Uni-track. From front to back are Rust, Railroad Tie Brown, and Rail Brown.

wanted the passings sidings to be as long as possible.

As I installed each turnout, I drilled a small hole through the roadbed directly under the position of the wires attached to the turnouts. I fed the red and black turnout wires (minus the plug) through the hole and, like the power leads, left them dangling.

I've always liked the look and sound of crossings, and it was my Norwegian visitor and benchwork-building buddy Stener Harildstad who suggested the configuration that put the diamond between the engine terminal and furniture factory. Getting those sidings far enough away from the backdrop to make reasonable-looking scenery possible was a bit of a challenge. You can see in **fig. 7** on page 36 that the jog in the tracks going to the furniture factory and enginehouse is there to move them away from the backdrop.

The passing siding is a little closer to the edge of the layout than I would have preferred, but the curve diameters of the superelevated tracks on the Meadow Valley Wash side determined where everything – track, turnouts, and structures – would be on the Caliente side.

I can't overstate how challenging it was to connect, without kinks or gaps, the double track at the left end of the

yard to the double track at the right end. The curved sections all had to be precise to keep the track spacing consistent. I wish I could say my track planning skills made it work, but I majored in English, not math, and geometry definitely isn't my strength. It was all a matter of trial and error.

Speaking of consistent track spacing, here's a simple little tip. On a notecard I marked the spacing I wanted between tracks (main line in red, passing tracks and yards in black). As seen in **fig. 8**, the mainline spacing through the yard simply continues the spacing between the rails on the superelevated sections. Then, when I eventually came to spiking down the tracks, I used the marks as an alignment guide. I also used a long straightedge, shown in **fig. 9**, to keep the track arrow-straight.

### Last puzzle piece

During a visit to the hobby shop, I saw a short section of track on the Kato rack. It looked like a grade crossing, with simulated wood planks running parallel to and between the rails. Closer examination revealed that it was an expansion section, meaning that it was a flexible length – anywhere between 3" to 4 1/4". See **fig. 10**.

This track section changed everything. In addition to using the expansion tracks as "fitters" to provide the needed, but unavailable, track lengths, I used them as grade crossings. So, I ended up using about a dozen.

I used Kato track section 20-048 (with bumping post, shown in **fig. 11**), at the end of each of the intermodal yard tracks and furniture factory sidings. I

used the bases of the enginehouse and furniture factory kits to assure there would be room for these buildings. I even cut the enginehouse floor to accommodate the track clips.

In **fig. 12** you'll notice that the tracks going into the enginehouse aren't parallel. The turnout angle didn't match the spacing of the track grooves in the enginehouse floor.

### Painting the rails and the ties

I used a set of Floquil's track weathering markers to tone down the shiny Kato Unitrack, as shown in **fig. 13**.

I started by painting the rails using the Rail Brown marker. I set the marker's tip in the web of the rail and dragged it along the track. I used it on both the inside and outside of the mainline rails and along the passing sidings and intermodal tracks. I used the Rust marker along the diamond, furniture factory, and enginehouse tracks, suggesting that they're not heavily used. I cleaned any paint off the railhead with a track cleaning block.

After studying prototype photos in Mark Hemphill's *Union Pacific Salt Lake Route*, I could see that in real life the ties and ballast between the rails get heavily discolored as well. So, I next dragged the Railroad Tie Brown marker between the rails. Later, the crew at MR used an airbrush and thinned Polly Scale paints to further weather between the rails and along the edge of the ballast.

With the track in place, it was nearly time to try running some trains. Next month, I'll explain how I wired the layout for Digital Command Control. **MR**

### Now on ModelRailroader.com

Registered users can read Dick's log book entries as he built the layout during a 10-month period, and subscribers can take a video tour of the Salt Lake Route at [ModelRailroader.com](http://ModelRailroader.com).





# The Salt Lake Route part 4

# Wiring a small layout for DCC

Plug-and-play components are easy to install and yield great results

By Dick Christianson • Photos by the author



Dick Christianson explains how to wire the Salt Lake Route for Digital Command Control. He concealed the system's command station in a drawer built beneath the layout's intermodal yard. Bill Zuback photo



All right, I'll fess up. Wiring is not my strong suit. I grew up with AC tinline trains and still find even that a little challenging. I understand the principles of DC cab control wiring, and I've read all of Kalmbach's wiring books as well as pretty much every article *Model Railroader* has published on wiring, electronics, and Digital Command Control (including Bruce's Chubb's and Keith Gutierrez's early features on command control). Between 1978 and 2007, I served as both a magazine and book editor at Kalmbach Publishing Co., so that's what I was paid to do!

Reading and doing, however, aren't exactly the same.

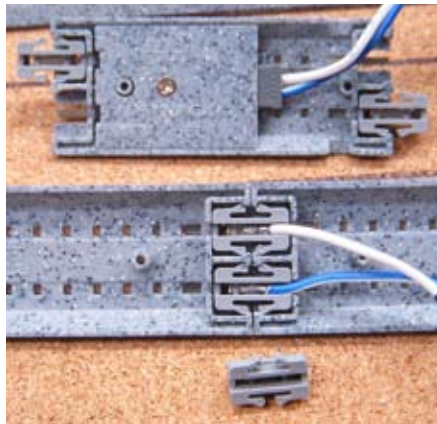
When MR's editors called about this project, they gave me the choice of using block wiring, but they preferred Digital Command Control (DCC). Progressive (and maybe a little lazy) person that I am, I thought about it briefly and opted for Digitrax DCC. My reasoning? In theory, DCC requires only two wires from the command station to the rails, and that's it. In theory.

### Idiot-proof DCC

In fact, I learned to my considerable pleasure and relief, it really didn't take much more than that. Also to my pleasure and relief, the trains ran just fine the first time I fired up the N scale Salt Lake Route layout. I'd gotten it right the first time! (I'm still a little surprised that the trains actually run when I turn on the power.) That being the case, I can only assume that DCC, at least in this simple form, is pretty much idiot-proof.

This layout uses Kato Unitrack, but the firm doesn't offer a DCC system. However, its DC plug-and-play control system is as close to foolproof as you could make it. If you're using Unitrack but really not interested in DCC, go ahead and use Kato's DC wiring system. The turnouts are power-routing, and Kato sells insulated rail joiners to make block wiring easy. The feeder tracks and the combination feeder joiners/clips, seen in **fig. 1**, come ready to plug in; Kato also offers extension wires for longer runs. Though I wired the Salt Lake Route for DCC, much of what follows applies to both DC and DCC.

Once you've removed both of the original connectors from the end of the appropriate track sections, simply insert Kato's feeder connectors into the openings molded into the roadbed and push on them until they snap into place. Once again, be sure to orient the blue and white wires to the correct rails to avoid an accidental short circuit from reversed polarity. I cut off the large



**Fig. 1 Power feeders.** Last month Dick explained how to install Kato Unitrack power feeders during tracklaying. He used plug-in sections on the straight tracks, while the joiner type worked better for the curves.

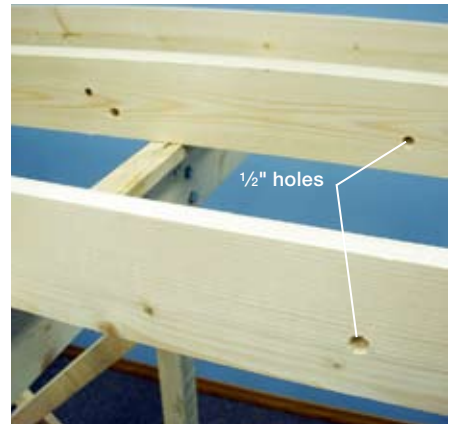
plug from the opposite end of the blue and white wires and fed them through the holes I drilled in the layout's surface. I left the wires hanging until it was time to connect them.

By the way, because of the way my friend, Stener, and I designed the folding benchwork, nothing can be allowed to hang down between the layout's L-girders. That space is reserved for the leg assemblies. That being the case, we drilled a couple of 1/2"-diameter holes through each joist, **fig. 2**, and ran the wiring through these holes to keep it neat and clear of the folding legs.

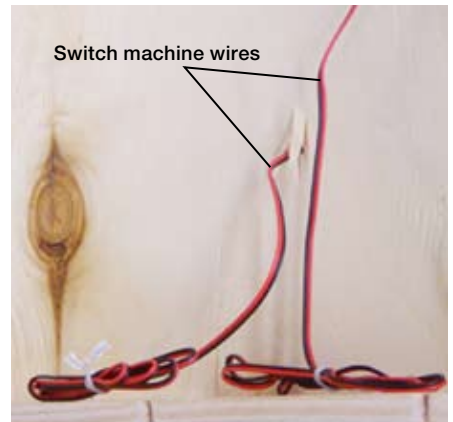
### Turnouts

Kato's switch machines are hidden under the turnout inside the molded roadbed. A small black tab next to the points actuates the turnout manually. The tab is unobtrusive and blends into the background. The turnout's action is positive, and the points make good contact with the stock rails. I had to use a small file to smooth the points a little on only two of the dozen turnouts I used (not including the crossover).

Like the feeder sections, the turnouts come with wires attached – one black, one red, and a big plug. As with the feeders, I trimmed off the plug so I could feed the switch machine wires through a small hole in the layout surface under the turnout. I left the blue and white track feeders dangling, but since I wasn't going to wire the switch machines (the turnouts all can be aligned manually), I fed the red and black wires through the plywood, coiled them up, and tacked them to the side of the joist so they'd be out of the way. See **fig. 3**. I was careful to keep the staples from penetrating the wire insulation to avoid any potential short circuits.



**Fig. 2 Wire routing holes.** Because of the layout's design, nothing can hang down between the girders. Dick drilled 1/2" diameter holes through the joists so he could route the wiring through them and keep it clear of the folding legs.



**Fig. 3 Turnout wires.** Dick slipped the red and black wires down through the plywood, coiled them up, and stapled them to a joist.

### Command station drawer

Since all of the switching activity will be happening on the yard side of the layout, that seemed like the logical location for the DCC system's command station. Unfortunately, that's the side with the least space available. The area where the benchwork flares out on the Meadow Valley Wash side would be ideal, but that's open country and the trains just pass through without any reason to stop.

I located the DCC system in a drawer under the left end of the intermodal yard beyond the legs, as shown in **fig. 4**.

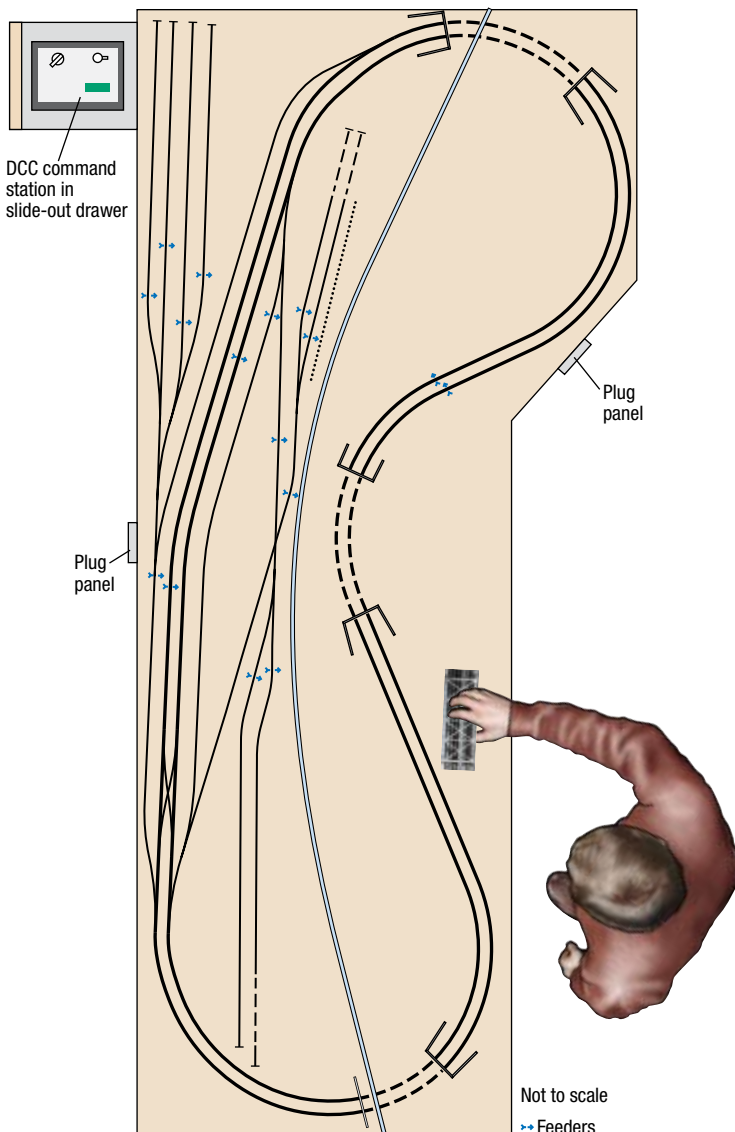
**» Union Pacific Salt Lake Route**

**January 2010:** Design  
**February 2010:** Roll-away benchwork  
**March 2010:** Track  
**May 2010:** Desert scenery





**Fig. 4 Control drawer.** The command station drawer is inset into the fascia. Dick made it using scrap material and drawer slides.



**Fig. 5 Location, location.** The location of the DCC command station and plug panels are shown on this track plan. The blue arrows indicate feeder wires.

I bought a pair of drawer tracks at the local home improvement center, used a piece of leftover plywood for the drawer bottom, and attached a piece of scrap 1 x 2 and the Masonite I cut out from the side as the drawer front. I wanted everything on the fascia flush, so I drilled a hole in the drawer front to serve as a drawer pull.

### Bringing it all together

Remember my comments about attaching two wires to connect the DCC to the layout? I ran a pair of 16-gauge bus wires, one blue and one white, from the Digitrax command station to a pair of barrier terminal strips mounted on a joist under the layout.

I could have run bus wires under the tracks and connected the feeder wires (indicated in **fig. 5**) to those. I know some modelers like to use the suitcase connectors (Scotchlok insulation displacement connectors) for this purpose. However, I was unable to find any small enough for the 24 gauge wires.

The layout is actually at a reasonable height for wiring. I was almost able to sit in a desk chair lowered as far as it would go – almost, but not quite. So I began the wiring process on my hands and knees with my head bent back, which wasn't very comfortable. When I was about halfway done, my wife, Diana, came down to the basement to check on my progress. She asked, "How about folding the legs up and tipping the layout on its side?" A great idea. In fact, it was such a great idea that I was able to wire the layout more comfortably. See **fig. 6**.

I numbered each pair of feeders at the point where they came through the plywood; I also numbered each of the connection points on the terminal strips. This probably isn't necessary on such a small layout, but it'll help in troubleshooting if problems arise later.

Back to the two wires from the DCC command station. One of the terminal strips is for the blue wires; the other is for the white. See **fig. 7** on page 66. These particular strips have continuity from top to bottom, but not side to side. To use them as I have here, I stripped a couple feet of insulation from the end of both the 16 gauge white and blue wires.

After loosening all of the lower screw terminals, I looped the bare wire over the first screw, pulled the insulation up close to the terminal, and tightened the screw. Then I looped the bare wire up and around each screw in turn and tightened the connections as I went along. That made all of the screw terminals live. Then I did the same with the



## ► Materials list

### Digitrax

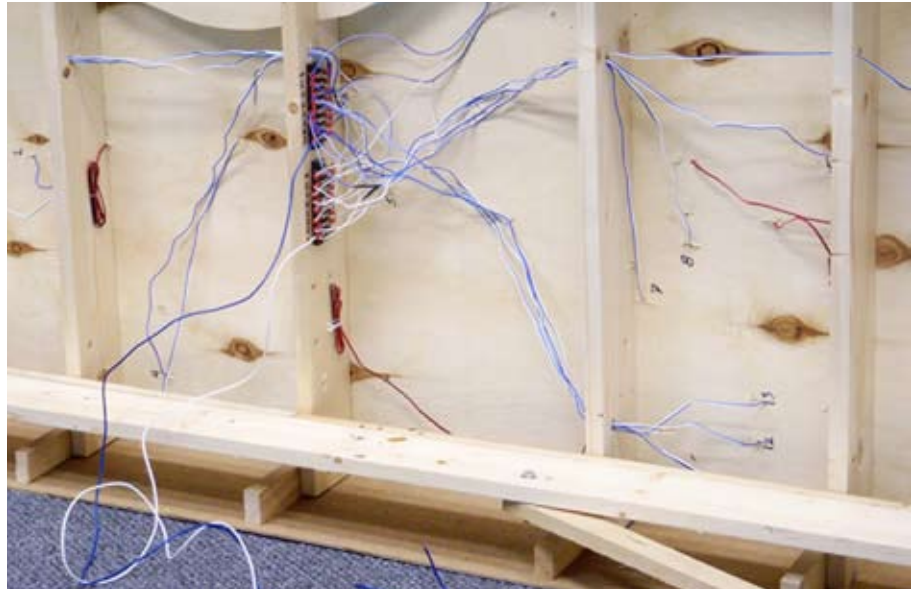
DCS50 Zephyr Digital Command Control system  
RJ12 cables, 48" long, 2  
RJ12 plugs, 4  
UP5 universal interconnect panel (remote terminal), 2  
UT4 throttle, 2

### Kato

24818 terminal joiners, 8

### Miscellaneous

32 wire terminals, fork type  
Barrier terminal strips, 2  
Drawer tracks/slides, 12", 1 pair  
Rosin soldering flux  
Solder  
Wire, 24 gauge, blue  
Wire, 24 gauge, white



**Fig. 6 Wiring access.** Dick began wiring the layout on his hands and knees. Then his wife, Diana, suggested he tip the model railroad on its side so he could wire the layout from a more comfortable position.

white terminal strip. Later on, I found out that most terminal strip manufacturers sell bridge connectors that fit under the screws to do this job.

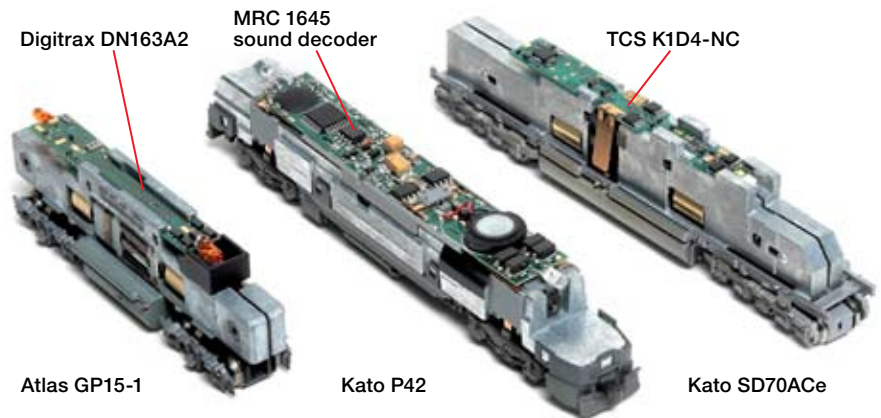
### Tiny wire troubles solved

I could have just stripped the insulation from the ends of each of the stranded feeder wires, wrapped them around the terminal screws, and tightened them down. But I was a little bit concerned about stray strands of wire causing a short circuit. So, I bought spade lugs to make everything more permanent and neater. However, the openings in the smallest spade lugs were too large for the wire, so there wasn't any way a crimping tool could squeeze the lug onto the wire tightly enough for a good connection.

To resolve this problem, I stripped about an inch of insulation from the end of each wire, folded the bare wire over on itself at about 1/2", and twisted it – effectively doubling the gauge. I fed that through the hole in the shank of the spade lug, tinned it, and soldered it. This trick would probably work just as well with a crimping tool, but I didn't have one so I went with soldering the joints. They'll hold forever.

At this point, finishing the wiring was just a matter of sliding the spade lugs under the appropriate screw terminals and tightening them down. Having done that with all 16 feeder pairs, I set the layout on its legs, plugged in the command station, and placed a decoder-equipped locomotive on the track. Much to my pleasure, it ran smoothly everywhere! Next, I added a second DCC locomotive to the track,

## Installing N scale DCC decoders



**Since I'm the resident N scaler on staff,** it fell to me to install the decoders in the locomotives for the Salt Lake Route. I used drop-in decoders from Digitrax, MRC, and TCS. For those of you new to DCC, drop-in decoders are made to replace the circuit boards in particular N scale locomotives, so make sure you purchase the correct ones for your models.

To install the decoder, simply loosen the screws that hold the frame together, remove the old circuit board, and set the decoder in its place. You may need to add a small amount of insulation between the frame and the decoder (usually a piece or two of electrical tape), which will be outlined in the instruction sheet. After that, test the decoder on the programming track by reading back its address. You should get 03, the factory default. If everything checks out, program the address to match the locomotive's road number, and you're ready to run trains! – *David Popp, managing editor*

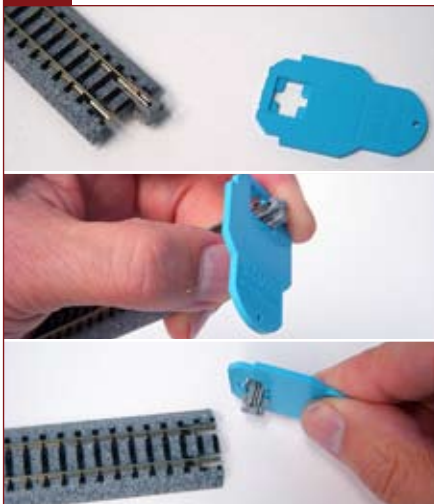
punched in the locomotive's address in the DCC system, and ran it around the mainline loop in the other direction at the same time.

You may be asking yourself, "Why 16 pairs of feeders? Why not just one pair?" The Kato turnouts I used are power-routing, so if I want to enter a

siding, the turnouts at both ends must be lined properly or the siding will be dead. With DCC, all of the track can be live all the time. So, feeder wires need to go to each side of the double-track main line on the Meadow Valley Wash side of the layout. On the more complex yard side, I installed 14 pairs connecting



## Kato clip removal tool



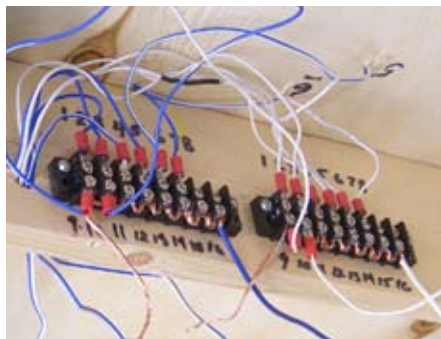
**Kato clip removal tool.** This bright blue plastic tool simplifies the removal of the rail joiner/clips from sections of Kato Unitrack. As the photo sequence shows, slip it over the joiner, rotate it 90 degrees, and then rock the joiner from side to side until it comes free.

**Before I realized** what the little blue device in the photos was used for, I struggled mightily to remove Kato's combination track clip/rail joiners from the track sections. Read the instructions? Are you kidding? I'm a guy. Well, eventually I read the instructions and found that this clever little piece of blue styrene worked really well and proved to be a real time saver.

Let me save you the frustration and lost time resulting from not reading the instructions. Here's how I removed the clip/joiners:

First, I grasped the blue styrene by the tab end (without the hole) and slid the hole over the clip/joiner with the tab positioned below the track (i.e., at 6 o'clock). Now rotate the device clockwise, so the tab end is pointing to 9 o'clock. Holding the tab, and keeping the clip/joiner in the hole, I pried and lifted the tab end away from the end of the track. It's like using a pry bar to lever the clip/joiner out of its socket from the left side first and then the right. It works great every time.

To turn the track piece into a feeder section, I replaced the removed clip/joiner (and fill the empty socket next to it as well) with Kato feeder clips. I also removed the opposite clip/joiner from the adjoining track. — D.C.



**Fig. 7 Terminal strips.** A pair of terminal strips make it easy to organize the layout's wiring. Labeling the wires helps troubleshooting later on.



**Fig. 9 Faceplate mounting.** Dick used small nuts, bolts, and washers to secure the faceplates.

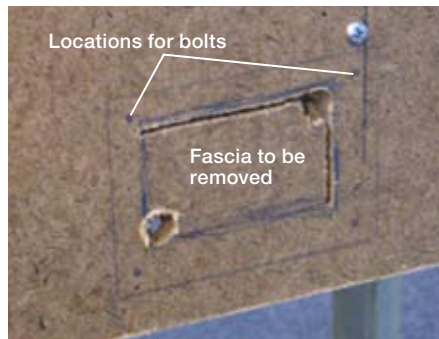
to the main lines, the passing sidings, the intermodal tracks, the industrial sidings, the engine servicing tracks, and both sides of the crossing.

## Remote control

Were I to build this layout for myself, I probably would have been content to run the layout from the command station alone. But MR's managing editor, David Popp, observed that it would be good to have a socket for a handheld throttle on the other side of the layout for a second operator to keep an eye on trains passing through the Meadow Valley Wash.

Perhaps more important, he noted that having the command station drawer open all the time was a little awkward, and the manually-operated turnouts were out of reach at the opposite end of the yard. Valid points.

So, I found a spot on the angled fascia of the Meadow Valley Wash side that wouldn't interfere with the retractable legs. Using the faceplate of the Digitrax plug-in panel as a template, I made pencil marks where the screw holes would be. See **Fig. 8**. Then I placed the plug module against the fascia and marked how large a hole I'd need to fit the plugs through. I drilled  $\frac{1}{4}$ " corner holes and used a keyhole saw to cut the center opening. Since there



**Fig. 8 Position faceplate.** Dick used the Digitrax faceplate as a template to mark the fascia for the mounting bolt holes and the cutout for the sockets.



**Fig. 10 Loconet.** A cable connects the plug panel to the Loconet socket on the back of the command station.

was nothing solid enough behind the fascia to hold any screws, I drilled holes through the fascia for small bolts that I used to secure the faceplate.

Next, holding the plug module in place from behind the fascia, I positioned the faceplate, inserted the fasteners, and tightened them down as seen in **fig. 9**. All that was left was to connect a cable from the command station to the remote plug-in unit, shown in **fig. 10**.

For the remote station at the other end of the yard, I simply followed the same steps. After painting the fascia I attached a strip of hook-and-loop fasteners to the fascia and its matching tape to the back of the handheld controller. The layout was ready to run.

The photo of the layout on its side in **fig. 6** shows that the basic wiring isn't what I'd call pretty. But it's effective, it's labeled, and it works. Phew!

Next month I'll begin adding the desert scenery on the Meadow Valley Wash side of the layout. **MR**

## Now on ModelRailroader.com

Registered users can read Dick's log book entries as he built the layout, and subscribers can watch a video on DCC for the Salt Lake Route online at [www.ModelRailroader.com](http://www.ModelRailroader.com).



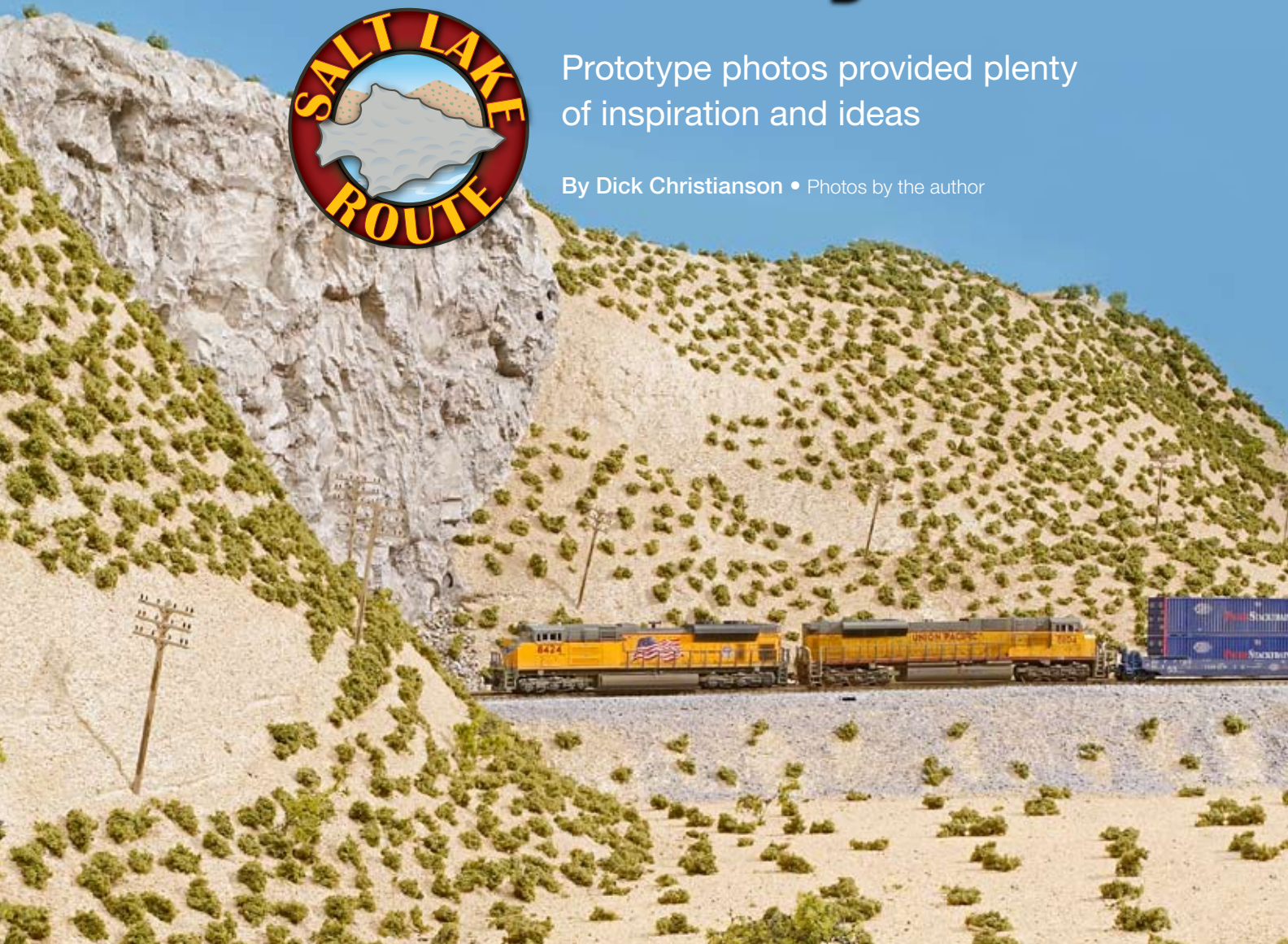
# The Salt Lake Route part 5

# Easy-to-build desert scenery



Prototype photos provided plenty of inspiration and ideas

By Dick Christianson • Photos by the author



**S**ome model railroaders enjoy laying track. Others get a kick out of wiring. I'm happiest when I'm building scenery. The desert landscape of the Meadow Valley Wash would be the signature scene of this layout, and I couldn't wait to get started.

My friend Stener Harildstad and I looked closely at the photos of the Meadow Valley Wash in Mark Hemphill's

book *Union Pacific Salt Lake Route*, which provided inspiration for this layout. Then Stener sat down with paper and pencil and sketched the Wash as he thought it might look on our N scale layout. [His vision is shown on page 41 of the January 2010 issue. – Ed.]

### Pink hills

On the last day or two before Stener was to return to his home in Norway,

Union Pacific road diesels lead a stack train along the Meadow Valley Wash. This month, Dick Christianson explains how he scenicked this side of our N scale project layout. Photo by Bill Zuback

we began cutting 1½"-thick extruded-foam insulation board. I used a sharp, serrated kitchen knife (bought specifically for this purpose – not borrowed from the kitchen). I'd tried a knife



blade in a saber saw, and that worked fine for cutting the general shapes. But for cutting the slope into the edges, the serrated knife worked better.

The idea is to cut the first piece to the shape of the base of the hill – pretty much following a curved line an inch or so in from the edge of the track. Then we used the serrated knife to cut the edge to about a 45-degree angle, as shown in **fig. 1**, roughly matching the slope we had cut on the end fascia.

Next, we flipped that first layer of foam on its top and used it as a template for the next smaller layer of the hill. We did this until we got all the way to the top. The hill needed to reach its summit about one inch (at the ends) below the top of the backdrop.

At this point we had a rough form for the first hill (right end). We made cut-outs in the back edge of the foam to allow for the vertical backdrop supports, allowing the foam to seat flush. We also had to cut the tunnel through the first and second layers.

With the first hill in shape, we next cut the foam for the hill in the center of the layout, again providing a tunnel through the foam for the double-track main, as shown in **fig. 2**.

## Roughing it in

I drew a light pencil line on the backdrop along the tops of the hills. Where there were no hills (eventually to be rock cliffs), I drew a wavy line, suggesting that the tops of the hills and cliffs wouldn't be a straight line. Not having glued any of the mountains in place yet, I lifted off the stacks of foam and set them out of harm's way.

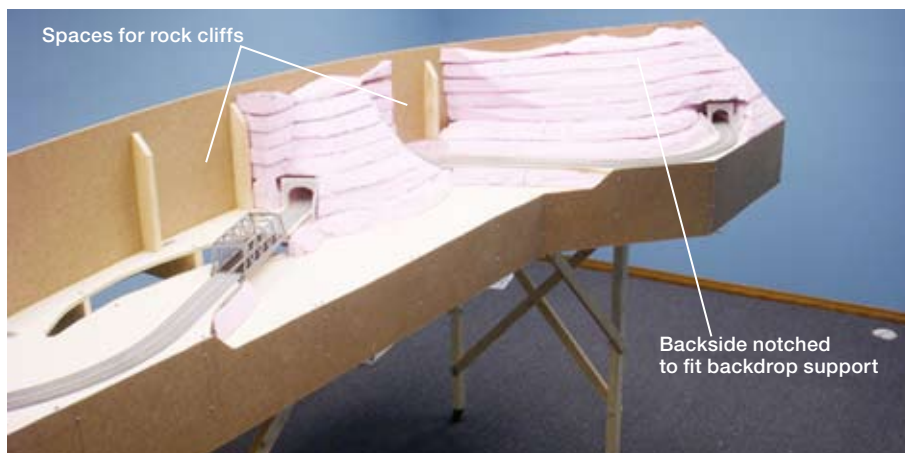
With a brush, I applied two coats of blue paint on the backdrop above and a little below my pencil line. When the paint had dried, I placed the first layer of the hills onto the layout, traced their location, and removed them. Then I applied beads of PL300 Foamboard Adhesive onto the plywood and set the first layer of foam in place. I next coated the top of the first layer of foam with adhesive and attached the second layer. I stuck pins through the foam so it wouldn't shift.

Next, I added the tunnel liner, which I made using 3"-wide strips of Woodland Scenics Track-Bed Sheets. I attached them to the foam with the PL300, as shown in **fig. 3** on the next page. I used pins to hold the roadbed material in place while the adhesive dried.

Before attaching the third layer of foam, forever precluding access to the tunnel interior, I added ballast along the edges of the plastic roadbed. I painted a band of Elmer's white glue along



**Fig. 1 Cutting foam.** Dick's friend Stener Harildstad used a serrated kitchen knife to cut the extruded-foam insulation board. The sloping contour of the foam roughly matches the railroad right-of-way.



**Fig. 2 Pink hills.** When Stener went home to Norway, this is how the Meadow Valley Wash side of the layout looked. Though the hills were in place, the layers were still removable so Dick could add the tunnel linings and ballast the track.

the edge of the roadbed and poured Kato's matching ballast onto it. When the glue had dried, I dribbled Woodland Scenics Scenic Cement onto the ballast with a small turkey baster.

With the tunnel liners in place and the edges of the track ballasted, I continued assembling the foam hills, layer by layer.

## Tunnel portals and bridge

Installing the portals was no easy task. With the foam hills permanently in place and the tunnel openings where they were going to be, I temporarily set the portals in place and pushed a double-stack well car through the openings in both directions on both tracks to check for clearance.

I attached the portals to the underside of the third layer of foam – a bit high – and then filled in underneath. This was the only way I could get the loaded well cars to go through freely. I applied PL300 to the openings and hung the portals with masking tape until the adhesive set. I also used

chunks of foam to support the portals temporarily. I used the same techniques to attach the wing walls. This completed the basic work on the hills that are above grade level.

Next, I shaped the pieces of foam to make a slope between the creek and track level; PL300 held these in place as well. Since much of the "headwaters" of the creek will be visible from one angle or another, I filled in the gap between track and creek level all the way back into the eventual canyon.

The Kato bridge spanning Meadow Valley Creek is a beauty, complete with

## ►► Union Pacific Salt Lake Route

**January 2010:** Design

**February 2010:** Benchwork

**March 2010:** Track

**April 2010:** Digital Command Control

**Coming next month:** Scenery for Caliente, Nev.

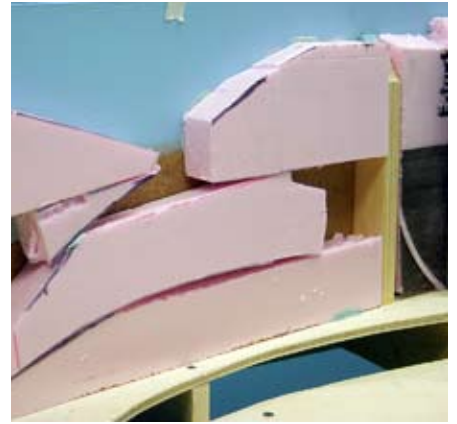




**Fig. 3 Tunnel linings.** Before enclosing the tunnel, Dick lined the walls with Woodland Scenics Track-Bed.



**Fig. 4 Bridge details.** Dick trimmed the Chooch bridge abutments to fit under the Kato bridge.



**Fig. 5 Needed depth.** To give the Noch rock walls added depth, Dick attached scrap foam to the backdrop.



**Fig. 6 Blending the rock walls.** Dick rotated some of the Noch rock walls so the patterns wouldn't be repeated. He also shortened some to vary the height. He used Sculptamold to fill the gaps between the sections.

shoes that rest on the bridge abutments. I picked abutments from Chooch, measured the distance between the shoes and the plywood, and used a razor saw to cut the abutments to fit. I fashioned wing walls from the abutments as well and carved out the foam to accommodate the piers and walls. I used PL300 to affix these to the plywood. See **fig. 4**. I added pieces of foam to blend the wing walls into the embankments going down to the creek.

## Rockwork

I first came across the Noch rocks when I was building my large O gauge Lionel layout during my tenure as editor of *Classic Toy Trains* magazine. The rocks come in 8" x 13" factory-painted sheets, are lightweight, and are made of a very dense and easy-to-cut foam.

I needed to build three sections of canyon wall: a short one, a long one, and

a double-sided one to hide the innermost part of the creek. In the case of the short and long walls, I varied the height and width of the slabs, and I tipped a couple end for end to make sure that the rock pattern didn't repeat itself. I used a serrated knife to make a clean, straight cut through the foam so I could butt the edges together neatly.

I didn't want to cement the rock outcroppings directly to the backdrop, so I used PL300 to first cement scraps of foam behind them to give the bluffs a little more depth, as shown in **fig. 5**. Then I used PL300 to attach the rocks to the foam scraps, as in **fig. 6**. I also cemented scraps to the backdrop at the very tops of the cliffs to hide the gap and to form the tops of the bluffs.

## The disappearing creek

Hiding the source of the creek on the far side of the tracks was a bit of a

challenge. I ultimately built a two-sided rock outcropping. Perfect solution? No, but no one who has seen the layout has commented negatively about it.

I placed two pieces of the foam together back to back and cut them to the shape I wanted. I also cut into the foam hill at the far left end to make the outcropping appear to come out of something, as shown in **fig. 7**, opposite. With the two sides cemented together, I set this rock aside. Had I cemented it in place, finishing the scenery behind it would have been much more difficult.

With the problem of the disappearing creek solved, I turned to the creek itself. Perhaps I could have just used the plywood to form the base of the wash, but I wanted a little bit of depth for the streambed. To simulate this, I cut pieces of 1/8" tempered hardboard to cover the plywood base, except where the channel of the creek would be, as in **fig. 8**. I used Elmer's Carpenter's Glue and short drywall screws to fasten the hardboard. Then I added another layer of hardboard, set back an inch or so, giving a stream depth of about 1/4".

## Shaping the hills

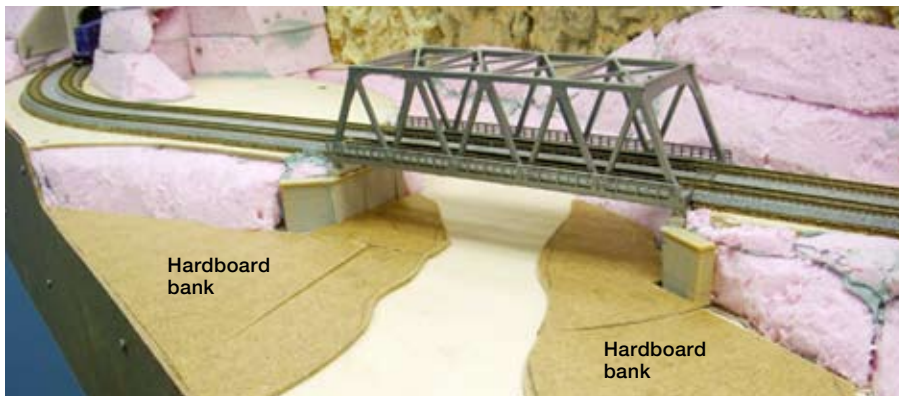
While cutting the extruded-foam insulation board for the hills, I hadn't spent a lot of time or effort shaping them precisely. With all of the chunks glued together and in place, I got out my Stanley Surform and started shaving away the mismatches. Then, as the seams became smoother, I switched over to rubbing 3M SandBlaster sanding sponges over the entire surface of the hills.

The horizontal seams between the layers of foam need to be hidden or they'll show through the ground cover and make the hills look like a layered wedding cake. Sculptamold troweled onto the seams is a good start. I also applied a thinner coat of Sculptamold





**Fig. 7 Visual trickery.** Meadow Valley Creek needed to disappear into a canyon, so Dick made a two-sided rock wall by gluing rock sections back-to-back. The dense foam is easy to cut, so carving the edges to match requires little effort.



**Fig. 8 Adding banks.** To give the streambed some profile, Dick attached 1/8" tempered hardboard to the top of the plywood. To match the 1/4" of fascia above the top of the plywood, Dick added more hardboard.

over blemishes in the foam. See **fig. 9** on the next page. When this dried, I went back with the sponges and smoothed the seams and other rough spots.

### Blending vertical seams

The Noch rocks aren't necessarily made to be pieced together side by side. Where there are outcroppings on one piece, there may very well be indentations on the adjacent piece when you butt them together. Where this occurred, I used a hobby knife to carve away the outcroppings to more or less match the indentations.

My next step was to mix a batch of Sculptamold to a consistency similar to oatmeal. Then, using a small palette knife, I worked the Sculptamold into the gaps along the vertical seams. In some areas, I had to build up the Sculptamold so the two edges matched. I did the same with the seam along the top of the rock wall that hides the disappearing creek, as well as along the banks of Meadow Valley Creek itself.

### Painting the rocks

Though the Noch foam rocks come painted, the cutting and carving didn't

do much for their finish. I painted the two rock walls and outcroppings with gray latex paint.

Next, I put a squirt of Mars Black acrylic artist's paint into a food container and thinned it with water to make a wash. I dipped a paintbrush in the wash and flowed the liquid on top of the rock castings, letting it run down as rainwater would. I coaxed the wash down the cliff here and there so it would catch in the crevices, as shown in **fig. 10**.

In looking more closely at the photos and reading the text and captions in Hemphill's book, I noticed that he comments on the orange color of some of the rocks. To suggest just a hint of this, I mixed a little Titanium White and Burnt Umber acrylic paint, adding white until I got an orange tint. Then I drybrushed the paint on the rock castings with a flat-end brush.

If the low areas in the rock face are in shadow, then the high areas should be in light. To simulate the effect of sun on surfaces, I drybrushed the high points of the rocks with Titanium White. Just a hint of white, as shown in **fig. 11**, is all you need.

## Materials List

### Amaco

41819M Sculptamold

### Atlas Model Railroad Co.

2992 Union Pacific Ford F-150 pickups

### Bachmann

42506 telephone poles, 2 packages

### Chooch Enterprises

9832 double concrete bridge abutments

### Kato USA

24-039 N scale ballast, 3 bags

### Model Master paint

2910 Sand Beige

### Noch

58460 sandstone rock wall

### Pre-Size Model Specialties

214 tunnel portals, 5  
215 abutments/wing walls, 10

### Polly Scale paint

414275 Roof Brown  
414323 Rust

### Woodland Scenics

191 Scenic Cement  
198 Scenic Accents glue  
571 dry transfer railroad signs  
1133 fine-leaf foliage  
1279 gray talus  
1349 green blend blended turf  
1373 buff ballast  
1374 light gray fine ballast  
1478 Track-Bed  
1634 olive green underbrush  
2147 train mechanic figures

### Miscellaneous

3M Sandblaster sanding sponges, 60 and 80 grit  
Artists' acrylic paints: Mars Black, Burnt Umber, Titanium White, 1 tube each  
Carpenter's glue  
Extruded-foam insulation board, 1 1/2"-thick 4 x 8 sheets, 2  
Liquid Nails for Projects  
Painter's tape  
Rust-Oleum Ace American Accents Soldier Gray (glossy)  
Pittsburgh flat latex paint, 54A-3 Harbor Sky  
Pittsburgh flat latex paint, N158 Palm Oasis  
PL300 Foamboard Adhesive  
White glue





**Fig. 9 Seamless blending.** Dick used Sculptamold to hide horizontal gaps and imperfections in the foam.



**Fig. 10 Adding depth.** After Dick painted the rock castings, he applied a wash of black acrylic paint.



**Fig. 11 High points.** To suggest shadows, Dick drybrushed the high spots on the rocks with white paint.



**Fig. 12 Spreading sand.** Woodland Scenics buff ballast captured the look of desert sand quite well.



**Fig. 13 Brush by the boatload.** Dick populated the hillsides with Woodland Scenics Olive Green underbrush.



**Fig. 14 Bald spots.** Where the terrain would be too steep for vegetation growth, Dick left the hillside bare.

## Talus

Once I finished painting the rock faces, I worked on the talus pile. Woodland Scenics talus was the right color (gray) and about the right size, though pretty uniform. I painted on full-strength Elmer's White Glue at the base of the outcroppings and then poured on some of the talus. To my chagrin, more of it rolled into the creek bed than stayed on the talus pile.

To fix this, I curved a piece of thin cardstock to generally match the curvature of the talus pile. Holding it near the bottom of the hill, I carefully poured on some talus. The card kept the excess from falling to the bottom. I carefully moved it up the slope as I continued pouring the talus out of the bag.

When that dried, there were still too many gaps. I applied more white glue to the gaps and sprinkled on pieces of talus. There are still some holes in the pile, but the overall effect is good.

## Ground (sort of) cover

The predominant look of the Meadow Valley Wash is tan sand and gray/green brush. I'd already decided to use

Woodland Scenics underbrush for the brush, but I hadn't figured out how I'd capture the look of millions of plants.

But first things first. I went to my local home center and picked out a paint color I thought would look right for the hills and brought it home. When I compared the color against the Woodland Scenics ballast I'd chosen to use as the desert sand, I realized once again that I can't trust my memory when it comes to colors. Back to the home center, but this time with the ballast in hand.

Starting at track level and working up until I had covered maybe a square foot of hill, I slathered on a thick coat of tan paint. While the paint was still wet, I sprinkled a thin layer of ballast onto the paint, staying an inch or so away from the edges of the painted area. That way when you apply more paint, you can overlap the paint without painting into a "sandy" area. I continued this process until the hills were covered with paint and sand, as shown in **fig. 12**.

The paint held most of the ballast, but some was loose on the surface. I soaked the sandy areas with Woodland

Scenics Scenic Cement so the granules would stay in place.

## Shrubs

I used Liquid Nails to attach the Woodland Scenics ground foam I used for desert brush. After plopping about 30 or 40 dots on the side of the hill, I broke off little shrubs and stuck them into the adhesive, as shown in **fig. 13**.

When I stepped back to admire my work, my impression was that the hill had chicken pox. My wife agreed. So did David Popp, MR's managing editor, when I sent him a photo. After discussing the problem with them, I decided the clumps were too big and too far apart.

I left a few of the steeper parts of the hillside bare, rationalizing that nothing would grow on a hill that steep! In fact,

## Now on ModelRailroader.com

Registered users can read Dick's log book entries as he built the layout during a 10-month period, and subscribers can take a video tour of the Salt Lake Route at [ModelRailroader.com](http://ModelRailroader.com).



the hills look more natural with a few bare areas. You can see the finished results in **fig. 14**.

## Meadow Valley Creek

To model the banks of the stream, I applied Sculptamold along the edge of the tempered hardboard, shaping it to a gentle slope. I also used Sculptamold to blend the hardboard into the foam sloping down from the tracks.

Next, I painted the entire creek bed with tan paint and then poured a thin layer of sand over the surface, as seen in **fig. 15**. In addition, I sprinkled a little bit of fine green ground foam along the banks of both sides of the creek.

A photo in Hemphill's book revealed a detail I hadn't thought of. The bed of Meadow Valley Creek has gray gravel in it. Apparently, small fragments of rock break off the nearby canyon walls and end up in the creek bed where they're carried along by the seasonal rains. That was easy to suggest by sprinkling fine, gray ballast onto the streambed. I secured the loose ballast with Scenic Cement.

When the cement dried, I used dots of Liquid Nails to hold in place rocks that I brought in from the woods behind my house. I also glued down a few twigs, also from the woods as in **fig. 16**; they're small, but big enough to look like fallen dead trees from growth along Meadow Valley Creek.

The photo on which I based this scene shows that trees had somehow managed to take root and grow near the bridge. I tore off delicate pieces of Woodland Scenics Fine-Leaf Foliage, picking pieces that looked like scrawny, scrubby trees. I drilled small holes in the sand-covered tempered hardboard, filled the holes with white glue, and set the trees in place. See **fig. 17**.

## Ballast

The molded ballast on the Kato track looks good; it looks even better once the rails have been painted and the ties weathered. Where the molded roadbed meets the ground, though, it still looks like sectional track because of the hard line between the plastic and the surface below it.

Kato sells a ballast color that matches the molded roadbed. I brushed white glue along the beveled edge of the roadbed and along the base. Then I used a small cup to carefully pour the ballast onto the glue, as shown in **fig. 18**. When the glue had dried, I used a soft-bristle brush to gently nudge extraneous pieces of loose ballast back toward the track. Having covered the rails with painter's tape, I then used a small turkey baster



**Fig. 15** Dry creek bed. Dick added green ground foam in the shadow of the bridge and along the creek banks.



**Fig. 16** Adding details. Rocks and twigs from Dick's back yard represent boulders and branches.



**Fig. 17** Trees. Though most of the vegetation on this side of the layout is brush, there are a few trees. Dick used Woodland Scenics Fine-Leaf Foliage to model the trees along the creek bed.

to dribble Scenic Cement over the ballast to hold the granules in place.

Where the tracks run close to the embankment along the wash, I poured Scenic Cement down the slope. Then I poured ballast down the hill after it, letting the granules tumble where they naturally would.

## Still more to do

Though I modeled the Meadow Valley Wash in mid-summer when it would be dry, adding water would be easy with a two-part resin or ready-to-use water product [see this month's installment of Step by Step on page 30. – Ed.]

Next month, I'll wrap up this six-part series by showing you how I scennicked the Caliente, Nev., side of the layout. **MR**



**Fig. 18** Blending the scenery. The hard edge between the molded roadbed and scenery didn't look realistic. To soften the transition, Dick brushed white glue on the edge of the roadbed and nearby scenery. With the glue still wet, Dick sprinkled on Kato's matching ballast.