

6 Railroads you can model



- ROOM-SIZE PLANS FOR BOTH HO AND N SCALES
- TIPS FOR MODELING HEAVY-INDUSTRY OPERATION
- EACH PLAN INCLUDES DETAILED INFORMATION ABOUT THE LAYOUT



Big Blue rolls on in the Motor City

The modern auto industry and a Conrail Shared Asset area highlight this N scale track plan

By Dana Kawala

Prototype railroad track charts can offer great inspiration for a model railroad track plan. While doing an internet search for railroads that served the auto industry, I found track charts for the Detroit District of Michigan's Conrail Shared Asset area. In this district, as in other shared asset areas, Norfolk Southern and CSX jointly control former Conrail property, and many of the diesels are still in Conrail's blue livery. Part of the Detroit District is the Sterling Secondary in my hometown of Sterling Heights, Mich.

Reviewing the charts, I imagined a switching layout that could fit into a spare room. After all, two of the main customers of this part of the line, a Chrysler assembly plant and a Chrysler stamping plant, were only a couple of miles apart. Then I went to Google Earth, a Web site that provides satellite views of most places on the planet, and received a dose of reality.

Automotive plants are massive and often connected to a mainline classification yard. In addition, a network of industrial track serves inter-plant

operations and connects the plants to outside vendors. It was clear that I had to make some adjustments if I was going to design a track plan for a relatively small space.

I ended up with this N scale plan that fits around the walls of a 10 x 12-foot room on a 2-foot-wide shelf.

Running "just in time"

Although I designed the track plan primarily for switching operations, I used wide-radius mainline curves and made the yard body tracks long enough to handle the maximum length of an eight-car train of 89-foot auto racks led by a pair of road diesels, such as SD70s or Dash 9s.

The main line runs between semi-hidden staging at Livernois Yard to Sterling Yard, and it's connected to the loading docks of the Chrysler assembly plant. The double-track main line turns into a single track just before entering the curve into the staging yard. This turnout lets the main line double as a runaround during switching moves at the stamping plant.

The Chrysler plant looms behind Sterling Yard. The auto industry inspired this track plan. Ray Sabo photo

Although the main line is short, following the prototype's operating rules helps lengthen the run. Along the Sterling Secondary, the maximum speed limit is 10 mph.

Industrial track serves the stamping plant on the outside of the main line and smaller industries located in front of the staging yard.

The track plan isn't designed for through trains. As on the prototype, Sterling Yard is the end of the line for most of the large diesels originating from out west. Most of the action involves classifying trains that enter the yard into locals that deliver loaded cars and empties to their destinations.

Road engines that bring trains north lay over in Sterling Yard until the yard accumulates a full train of cars to take back to Livernois Yard.

Industrial track that connects to the main line provides access to online industries. In addition to the Conrail Shared Asset local freights departing from Sterling Yard, industrial switchers make inter-plant runs.

The fun of operating an automotive-themed railroad comes with following prototype industry practice of "just-in-time" delivery. Auto companies don't want to pay for warehousing, but they also don't want to pay for workers sitting idle. The schedule of the entire

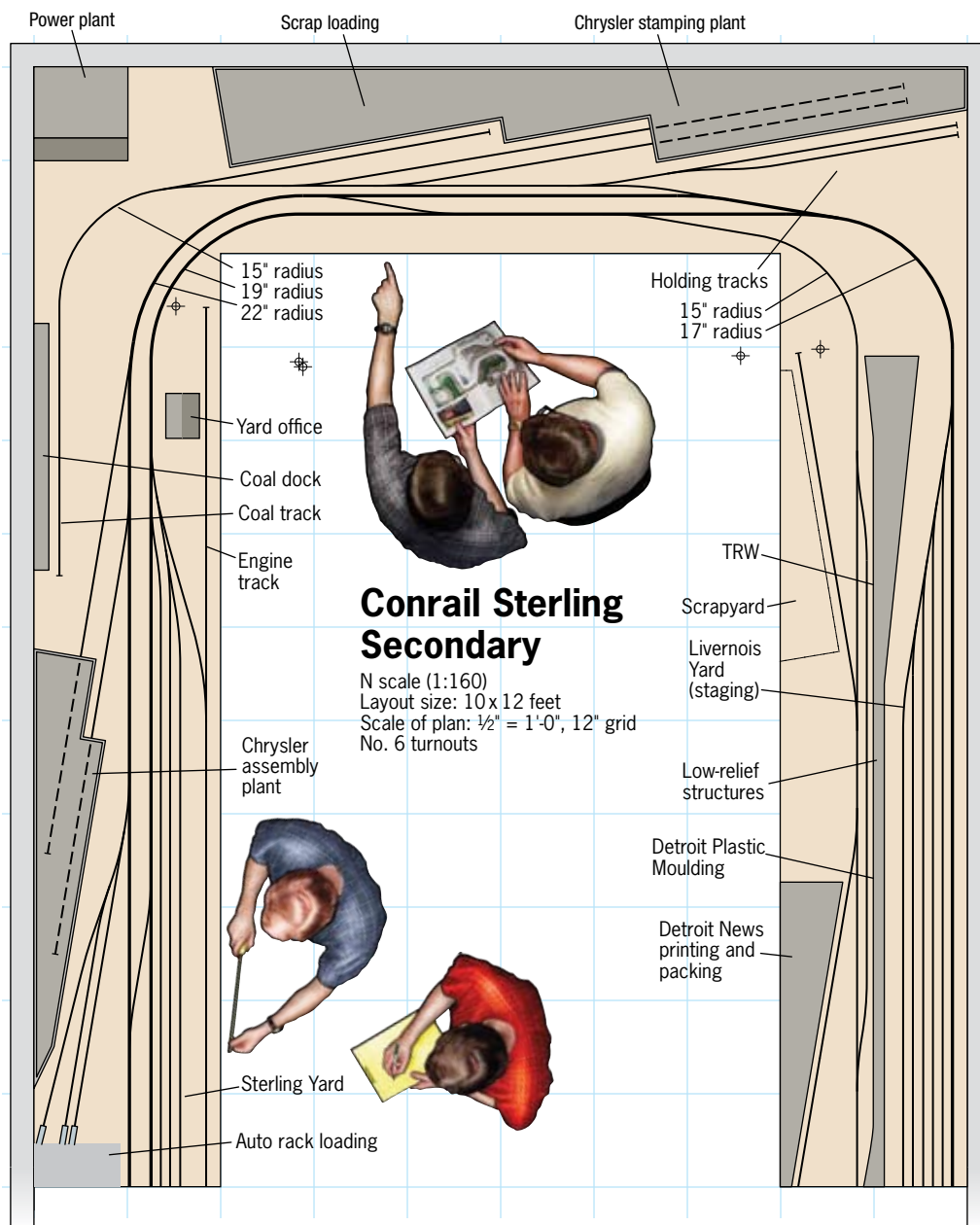

Illustration by Rick Johnson

supply chain is important. From trainloads arriving at Sterling Yard to locals setting out empties and picking up loaded cars to plant switchers delivering parts into the docks, everything needs to be done on time.

A variety of modern rolling stock

This track plan's setting allows for a variety of motive power. Although pairs of modern six-axle road diesels, as well as SD40-2s and SD60s, are primary power for mainline trains, four-axle GP15s and GP38-2s switch the yard and handle local freight traffic. Local power is in either Conrail, NS, or CSX livery, but the larger mainline diesels can also come from BNSF or Union Pacific. An industrial switcher makes inter-plant deliveries, such as moving cars from holding tracks to the docks.

For rolling stock, the auto industry relies on more than 89-foot auto racks. Typical freight cars include 50- and 60-foot hi-cube boxcars, 50-foot gondolas for scrap metal, coal hoppers, and covered hoppers for plastic pellets.

For even more variety, I added a non-automotive customer that I found on one of the track charts. The railroad delivers newsprint boxcars to the *Detroit News* printing and packing plant.

For most of the structures, I planned low-relief buildings along the walls. You don't need to model an entire mile-long factory, just the parts relevant to the railroad, such as loading docks. Low-relief buildings between the staging yard and south industrial tracks would define the scene in the front, yet still provide an operator with access to the yard in back.

▶▶ The track plan at a glance

- Name:** Sterling Secondary
- Scale:** N (1:160)
- Room size:** 10 x 12 feet
- Theme:** modern auto industry
- Period:** 1999
- Mainline run:** 24 feet
- Minimum radius:** 17" main line, 15" industrial track
- Minimum turnout:** no. 6, turnouts set at no. 5 angle in Livernois Yard
- Maximum grade:** none

For fans of urban railroading, the Sterling Secondary provides plenty of switching with enough mainline action to keep a few road diesels busy. **MR**

A 'plug-and-play' industry

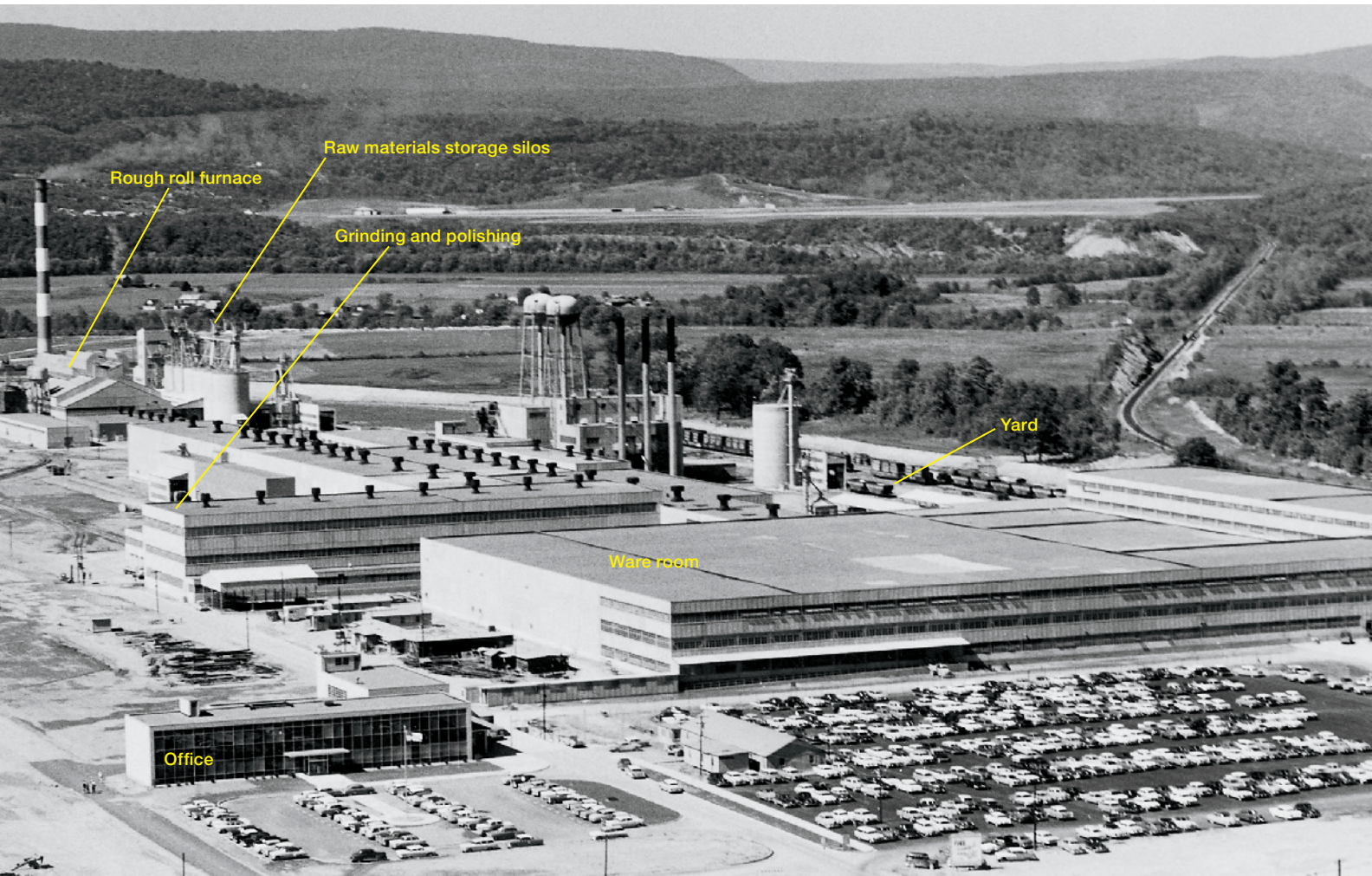

By Henry Freeman

Like many young model railroaders, I started with a basic loop of track on a 4 x 8 sheet of plywood. Years later, as my friend Bill Chapin and I worked on designs to add a major industry to my large HO scale layout, we realized the best approach to solve my space problem was to return to the 4 x 8 layout concept.

As a twist on the traditional plan, however, our self-contained industrial plant is made to “plug in” to the rest of the layout when needed and be moved out of the way when it isn’t.

A plug-and-play layout

By itself, my 4 x 8-foot Pittsburgh Plate Glass Works No. 7 plant is a self-contained industrial switching rail-

road, complete with a small interchange yard. The layout can provide hours of fun for a switch crew moving cars of time-sensitive raw materials in and around the glass factory. In fact, the plan only varies in two ways from a traditional 4 x 8 design: It has a three-foot single-track tail, which serves as the drill track for the plant, and there is no loop for continuous running.

When plugged into my B&O Cumberland Division during an operating session, the PPG plant always provides a steady stream of incoming and outgoing traffic for the rest of the railroad thanks to a connecting track at the end of the interchange yard. When the session is over, I unplug the 4 x 8 plant from the layout and store it under the railroad, freeing up valuable floor space in my layout room for working on other projects.

This is how Pittsburgh Plate Glass Works No. 7 plant in Cumberland, Md., looked in the late 1950s. At this point in its history, the float glass system has yet to be installed. Most of the plant could be kitbashed using various manufacturers’ stock kits and styrene shapes. Photo courtesy of PPG Industries

The prototype and the model

Pittsburgh Plate Glass started construction on the Cumberland Works No. 7 plant in 1954, installing a rough roll, flat glass furnace with a chemical polishing system. In 1963, PPG introduced to the world the first float line furnace, starting a new era in plate glass manufacturing technology. Once the furnaces were fired, plate glass production went on 24 hours a day, 365 days a year, and consumed huge amounts of raw material. PPG closed the Cumberland plant in the 1970s.

for your railroad

An HO layout doesn't have to be a loop of track

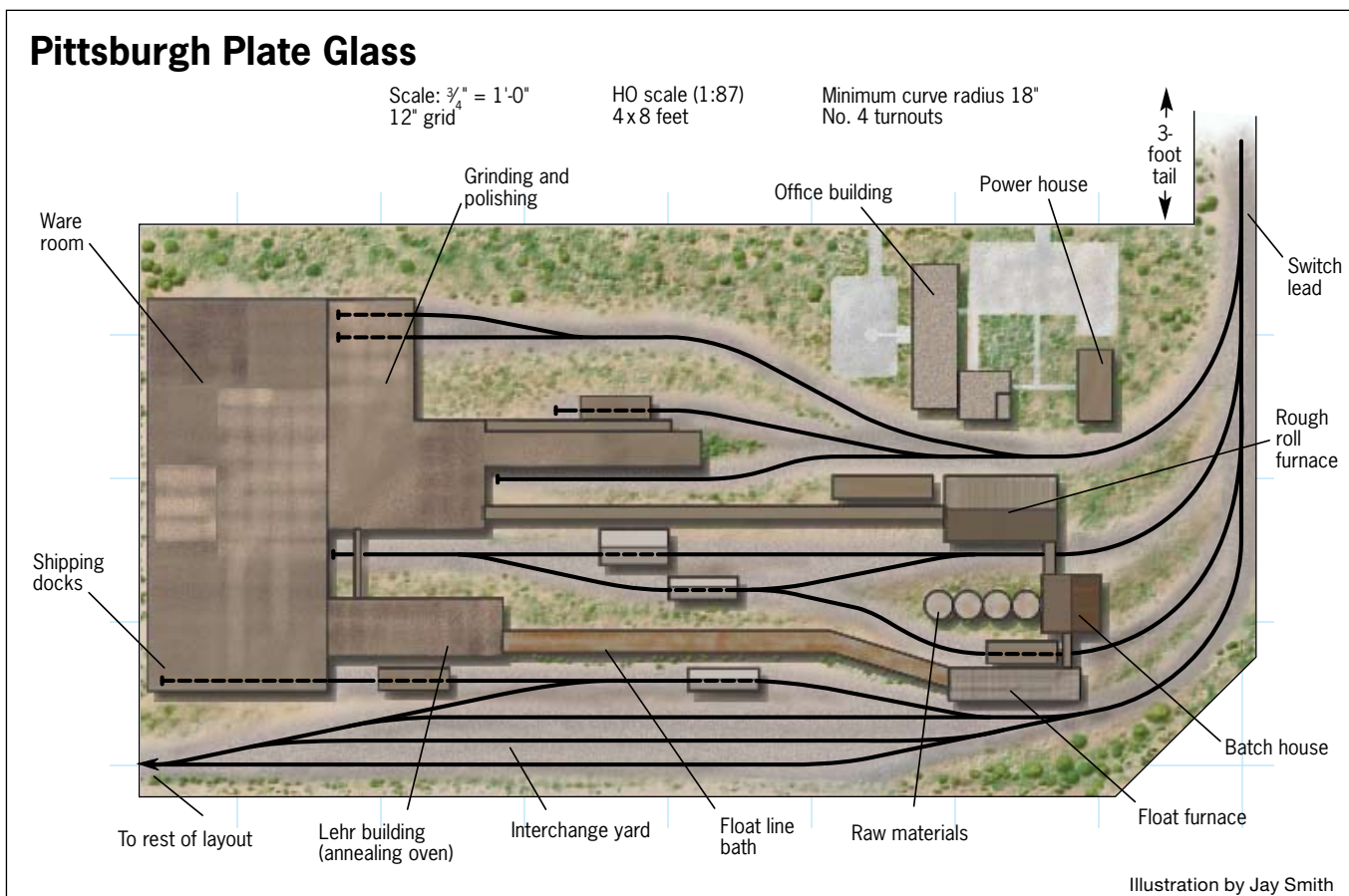

A glass plant receives its raw materials by rail and stores them in a series of silos. An intricate system of conveyers automatically gathers the materials from storage, weighs each to a specific formula, mixes them in a batch, and carries them to the melting tank.

Timing and continuity of the railroad shipments are of vital importance to keep a glass plant running. Soda ash, limestone, and sand are all delivered in covered hoppers. Salt cake, needed in the manufacturing process, rouge (iron oxide) and felt necessary for the polishing process, and packing material for outbound loads are all shipped in standard boxcars.

The Cumberland plant made plate glass from $\frac{1}{8}$ " to $\frac{3}{4}$ " thick and shipped it by truck, boxcar, and flatcar to customers for installation in store fronts and office buildings, processing by mirror manufacturers, and fabrication into automobile safety glass.

Though most of my PPG plant would involve scratchbuilding or kitbashing structures, you could apply this con-

Making glass

At one point in its history, Pittsburgh Plate Glass Works No. 7 plant was the only factory in the United States producing plate glass using both the traditional flat process and the new float technology side-by-side.

The major steps in traditional flat glass production begin with mixing and melting raw materials into molten glass. The molten glass is then rolled into a continuous solid ribbon, ground to a uniform thickness, and polished. The final steps include cutting, inspecting, and packing for shipment.

In the float glass plant, raw materials (largely sand and soda ash) are melted in a gas-fired furnace at over 2,800 degrees Fahrenheit. The molten glass flows out of the furnace as a continuous flat ribbon that floats on a bath of molten tin (which has a much lower melting temperature) until cool enough to hold its shape. Final processing further cools the ribbon, then it is cut into uniform sheets which are trimmed to sizes specified by customer orders.

Unlike the flat process that uses rollers to shape the glass, the float system produces glass with a perfectly flat surface. —H.F.

cept to other heavy industries that have large plants. Recently there have been plastic structure kits available for automobile plants, paper mills, and steel mills, so you would have a good starting point for the buildings.

Perhaps a plug-and-play industry is just what you need for your existing layout. Or it could be the starting point of your first model railroading adventure with plenty of room to grow as your modeling skills advance. **MR**

Naugatuck Valley in N

An apartment-sized New Haven layout with room to grow • By David Popp

As the last of the benchwork for my 11 x 30-foot HO scale Soo Line layout was unceremoniously shoved to the back of the storage unit, I figured it would be a while before I built another one. A recent move had caused my wife and I to temporarily downsize to a small apartment while we built a new house. Sensing my loss, however, she donated part of the living room for a small layout, and my plans for an N scale apartment-sized railroad were born.

A prototype with modelers in mind

Looking for something different to model than the Midwest, I sought out the New York, New Haven & Hartford for inspiration. After some research, I focused on the New Haven's Naugatuck Line, following the Naugatuck River Valley in Connecticut. This area was once rich with mills and factories and would provide some nice industries to switch. In addition, a devastating hurricane in 1955 caused the New Haven to rebuild most of the original double-track main line as a single-track one, making it ideal for a modeler with limited space.

The region also included some picturesque scenery as the New Haven wound its way north to Waterbury. Its dramatic, near-water-level route was surrounded by tree-covered rocky hills between towns and included some interesting bridges to model.

And by the late 1950s, daily traffic on the line was ideal for a small layout. It included a north and south through freight, a local serving the towns, and four passenger runs each way with Budd Rail Diesel Cars (RDCs).

The layout plan

Because of my space limitations, I knew my layout couldn't be an exact representation of the New Haven. With that in mind, the modeled towns of Seymour and Naugatuck exhibit the flavor of 1959 New Haven railroading in Connecticut but aren't accurate reproductions. Most of the structures can be easily kitbashed for the New England look.

I designed the layout in two pieces. The benchwork for the main part is a 32" hollow-core interior door covered with 2" foam insulation board. It has a completely independent loop for display running. For support, you can set the layout on an inexpensive folding table.

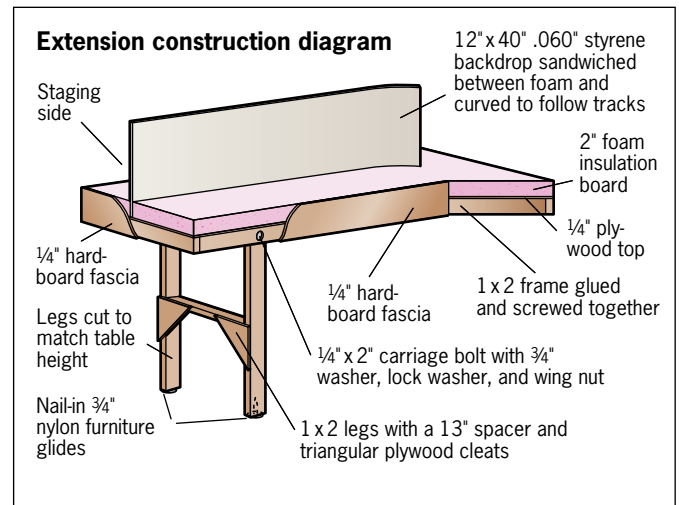
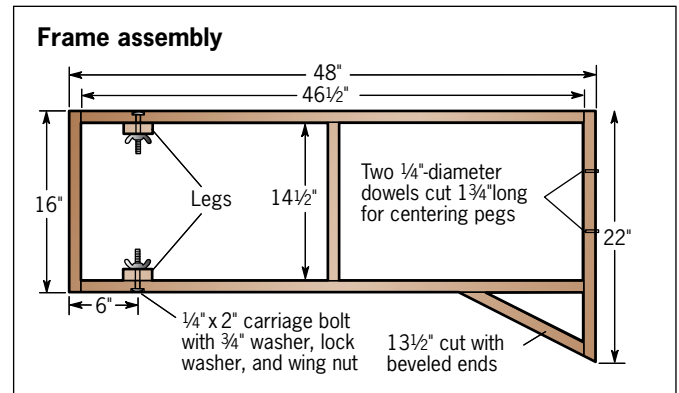

Moving freight on the Naugatuck

Late in the New Haven's history, the railroad would run a single freight north to Waterbury, Conn., each day. The train would have three locomotives, typically Alco RS-3s. In Waterbury, the crew would break up their train into three locals, sending them off in different directions to switch the main back to Naugatuck and the Torrington and Forrestville branches.

In the evening, the three locals would return to Waterbury, where the crew would reassemble the train and then take the whole thing back south to Cedar Hill.

By using the staging tracks as a fiddle yard, you could simulate this operation on this smaller version of the Naugatuck Line. Or, you could easily adapt the layout and its operation for your own railroad. —D.P.

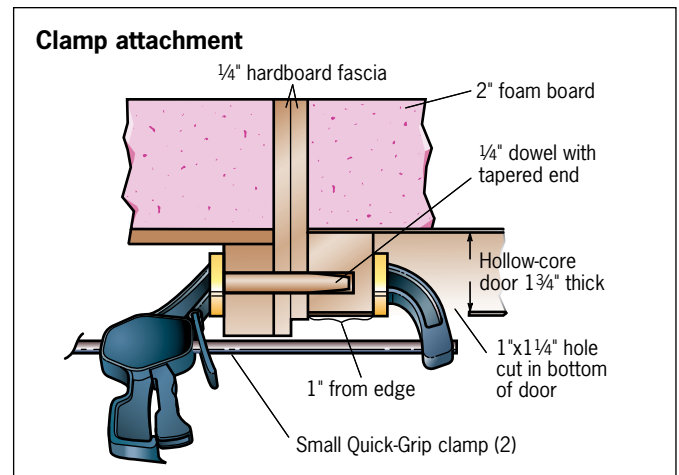

Illustrations by Jay Smith

Track and roadbed

Peco code 55 track

- 387 no. 8 curved right-hand turnout (2)
- 388 no. 8 curved left-hand turnout (3)
- 393 20-degree crossing (1)
- 1791 no. 4 right-hand turnout (1)
- 1792 no. 4 left-hand turnout (4)
- 1795 no. 6 right-hand turnout (3)
- 1796 no. 6 left-hand turnout (2)
- 1797 no. 7 wye turnout (1)
- 5801 36" flextrack (25)

Midwest Products

- 3019 cork roadbed (25)

Structure key

Atlas

- A. 2548 plate girder bridge

Bar Mills

- B. 304 low boy trestle (coal dock)
- E. 912 Whistle stop depot

American Model Builders

- C. 617 barn (used as fuel dealer shed)

Depots by John

- D. 6004 country station

Design Preservation Models

- F. 506 Gripp's Luggage (furniture factory)
- G. 660 Woods Furniture (kitbashed to fit backdrop)

Micro Engineering Co.

- H. 75153 40-foot ballasted-deck bridge (3 – cut to fit curve)

Model Power

- I. 1572 Jackson Meat (kitbashed into a textile mill)
- J. 1509 brewery (kitbashed into lumber mill)
- K. 1546 Holland Iron Works
- L. 1547 U.S. Customs (kitbashed into warehouses to fit backdrop)

Walthers

- M. 3246 Gold Flame coal dealer (modified to fit backdrop)

Scale: 1" = 1'-0"
N scale (1:160)
23.5 square feet

Minimum curve radius: 12"
All turnouts No. 4 unless marked
12" grid

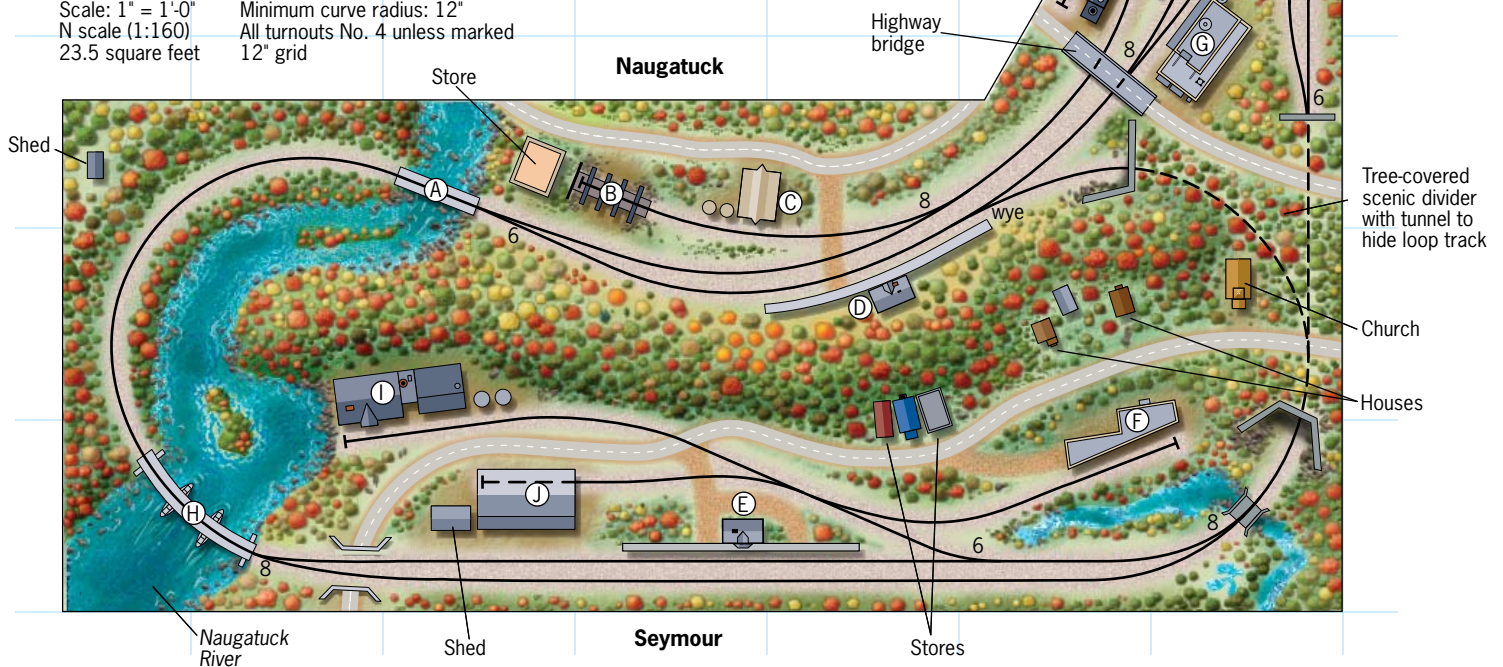

To gain a little more space and add some operating interest, I added a 16" x 48" removable extension. This piece allowed me to include a six-track staging yard (three tracks at each end of the railroad) and a 6"-wide industrial park for the town of Naugatuck.

When in use, the extension clamps to the layout with two Quick-Grip clamps and is supported by a removable leg. (To build the extension, see the construction diagrams.)

Fun for two

I designed the small layout with two operators in mind, and it would be a good candidate for an entry-level Digital

Command Control (DCC) system with walkaround control, either tethered or wireless.

For an operating session, using a simple timetable, one operator would run the local and switch the industries at Seymour and Naugatuck. The other operator would handle the through freights and the commuter passenger trains. The commuter trains would make station stops at both Seymour and Naugatuck.

Despite the Naugatuck Valley's small, apartment-living size, the plan has a lot of potential for expansion. Since completing the layout as shown here, I've added on to it three times, tripling the railroad's size. **MR**

Rails to the harbor

This 12½ x 17-foot HO scale track plan features the National Docks Ry. during World War II

By Howard R. Lloyd

After spending 20 years working on my HO scale Arvern Bay Terminal layout, I was ready for a change. Though I enjoyed scratchbuilding structures and modeling urban scenery on my old harbor layout [featured in the April 1991 and March 2000 issues of *Model Railroader* – Ed.], I'd maximized the model railroad's potential in terms of detail and operation. Still, I wanted to model a harbor scene, but on a slightly smaller layout. I finally settled on the track plan shown here for the 12'-6" x 17'-0" HO scale National Docks Ry.

When designing the track plan, set near my hometown of Jersey City and nearby Hoboken, N.J., during World War II, I had a few goals in mind. Tops was finishing the layout in five to seven years. The Arvern Bay Terminal (ABT) was a fun model railroad, but I wasn't ready to devote 20 years to another layout project. I also wanted a highly detailed layout. By selecting industries that lent themselves to detailing, such

as an export elevator and oil tank farm, I could achieve that goal.

With the industries selected and the track arrangement set, I'm ready to get started on my new layout.

Prototype history

The section of Jersey City and Hoboken, N.J., that fronts the Hudson River is about six miles long. During the early 1940s, most of this old marshland was crowded with railroad yards, terminals, piers, and rail-marine industries. The Central RR of New Jersey (CNJ), Erie, New York Central (NYC), and Pennsylvania RR (PRR) operated extensive yards devoted to handling, storing, and shipping cars either across the river to New York City or to other destinations.

A latecomer to the harbor railroad scene was the Lehigh Valley (LV). The railroad wound up with slivers of leftover marshland and had cramped access to the water. The railroad built and acquired three small terminals: Claremont, Jersey City, and Black Tom.

After studying the prototypes, I found Black Tom the most interesting of the three terminals.

At one time, Black Tom was a small island in the Hudson River. Then, in the late 19th century, thousands of yards of fill were dumped into the river to connect the island to the shore. The resulting peninsula was nearly 4,500 feet long and about 300 feet wide at its narrowest dimension.

The newly created land was then developed into the National Storage Co. freight terminal. There was a series of brick warehouses, open docks, a grain elevator, and an oil tank farm with harbor frontage on the peninsula. National Storage Co. was even served by its own railroad, appropriately named the National Docks Ry.

The Lehigh Valley eventually bought the National Docks Ry. and expanded it several miles north and south, renaming it the National Docks Branch. The branch linked the LV's three terminals and provided connections to the CNJ, Pennsy, and Erie.

Operating a harbor scene

Though operation wasn't my overriding consideration, I designed the plan so there would be a mix of transfer runs and switching. I could have expanded the layout to fill

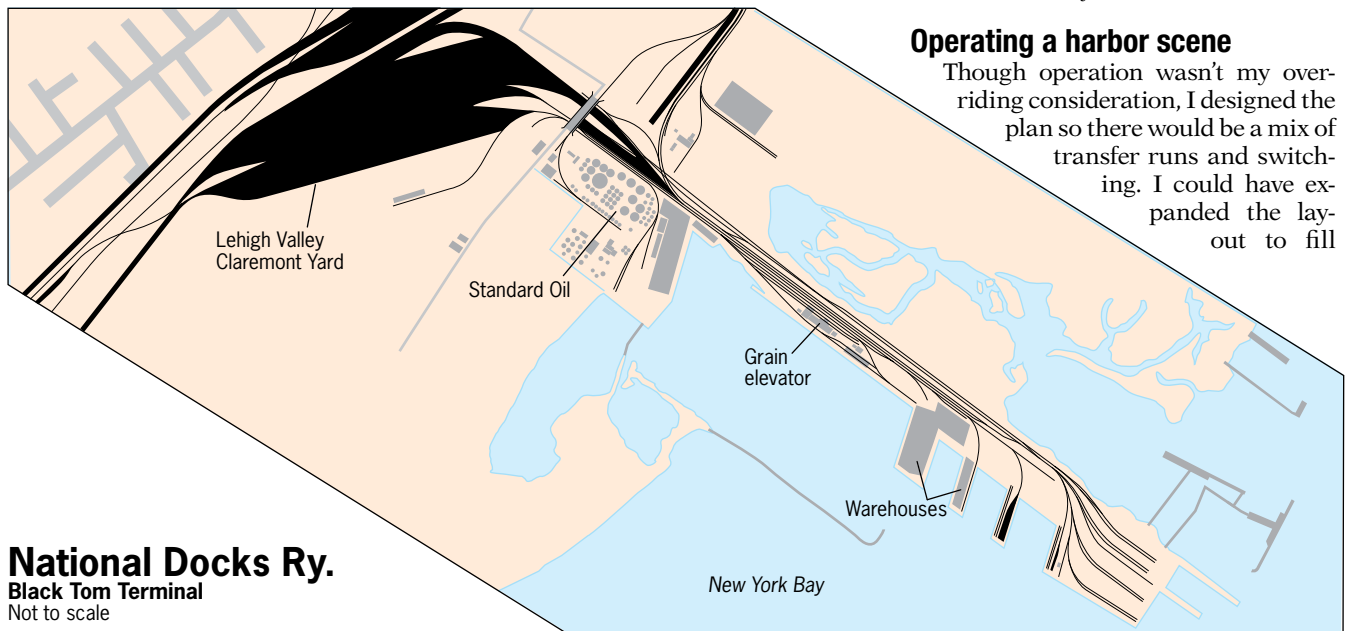

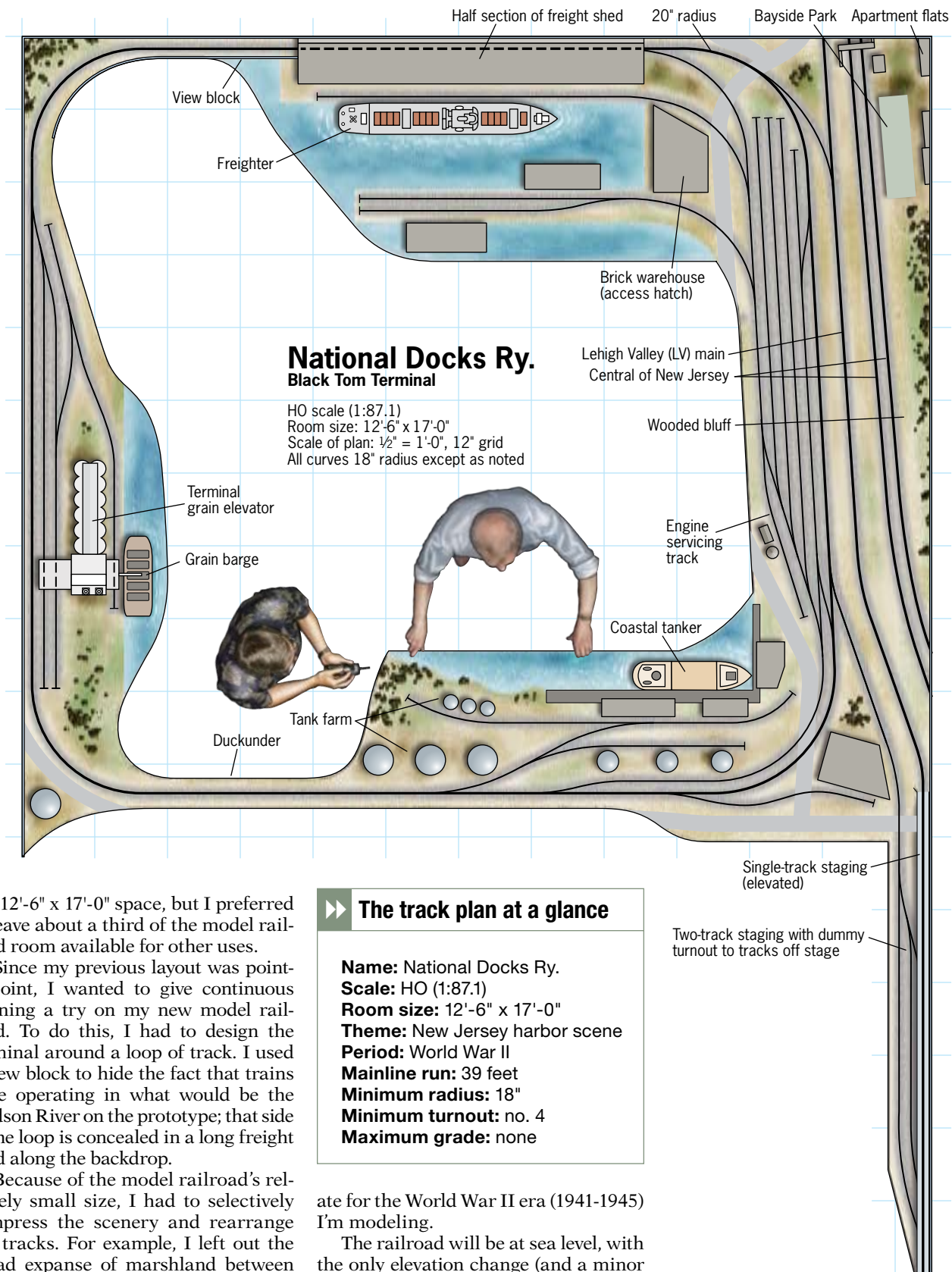

National Docks Ry. Black Tom Terminal

HO scale (1:87.1)
Room size: 12'-6" x 17'-0"
Scale of plan: 1/2" = 1'-0", 12" grid
All curves 18" radius except as noted

the 12'-6" x 17'-0" space, but I preferred to leave about a third of the model railroad room available for other uses.

Since my previous layout was point-to-point, I wanted to give continuous running a try on my new model railroad. To do this, I had to design the terminal around a loop of track. I used a view block to hide the fact that trains were operating in what would be the Hudson River on the prototype; that side of the loop is concealed in a long freight shed along the backdrop.

Because of the model railroad's relatively small size, I had to selectively compress the scenery and rearrange the tracks. For example, I left out the broad expanse of marshland between Van Nortstrand Place and the National Docks Ry. Black Tom terminal.

With curves 20" or less in radius, I'll use small steam switchers and four-axle diesels to serve the terminal, and I'll operate 50-foot or shorter freight cars. All of this equipment is appropri-

▶▶ The track plan at a glance

Name: National Docks Ry.
Scale: HO (1:87.1)
Room size: 12'-6" x 17'-0"
Theme: New Jersey harbor scene
Period: World War II
Mainline run: 39 feet
Minimum radius: 18"
Minimum turnout: no. 4
Maximum grade: none

ate for the World War II era (1941-1945) I'm modeling.

The railroad will be at sea level, with the only elevation change (and a minor one) being the wooded bluff rising above the CNJ tracks up to Garfield Avenue. I plan to set the benchwork height at 58".

Selective compression

According to my version of history, the National Docks Ry. is jointly owned

Single-track staging (elevated)
Two-track staging with dummy turnout to tracks off stage

Illustrations by Jay Smith



Howard's HO scale Arvern Bay Terminal RR was featured in the March 2000 issue of *Model Railroader*. Scenes similar to this could be modeled easily using the National Docks Ry. plan. George Hall photo

by the LV and ABT (which, in turn, is owned by the CNJ) and, for tax reasons, operated independently. All three railroads have trackage rights over the National Docks Ry.

Both the CNJ and LV main lines are depicted on the track plan, though the former tracks are purely cosmetic. The LV main, on the other hand, serves as a one-track staging yard for the National Docks Ry. In addition, I included two staging yard tracks at ground level that represent LV's Claremont Yard.

With only a 12'-6" x 17'-0" space to work with, I couldn't possibly include

all of the actual industries from the Black Tom terminal in my track plan. Instead, I selected three key areas from the prototype. Tops on the list was the Standard Oil tank farm. This was a distribution point for lubricating oils that arrived by tank car and left by harbor craft. Fortunately, I've already modeled the coastal tanker that will be tied up at the Standard Oil dock.

I also included a terminal grain elevator. This large, concrete structure received grain by boxcar and shipped it by barge. One of the elevator's major customers was Schaeffer Brewery in

Brooklyn, which received grain shipments directly by barge. Other barge loads of grain would be positioned next to ocean-going vessels loading cargo elsewhere in the harbor, and a floating grain elevator would transfer the grain from barge to ship.

Other items I added include a ship basin with an open dock, a brick warehouse (concealing a lift-out access hatch), and a half section of a large, corrugated-iron storage shed.

A three-island freighter, stick lighter, covered lighter, and a tugboat resting between assignments will be tied up in the basin. War materiel waiting to be loaded on ships to be assembled into convoys destined for Europe will be crammed on the docks.

Sabotage at Black Tom Terminal

During World War I, Lehigh Valley used Black Tom terminal in Jersey City, N.J., for the storage and shipment of munitions. Despite a city ordinance, the LV kept explosives within city limits. That was until July 30, 1916.

On that date, a fire of suspicious origin spread to a barge loaded with dynamite. The barge exploded, obliterating most of the warehouses and leaving a large crater and smoking ruins.

It was widely suspected that the explosion was the work of German saboteurs, a suspicion that was confirmed many years later through an examination of German records. Although the destroyed warehouses were never rebuilt, the other damage was repaired, and the terminal continued to operate with LV moving record levels of traffic to support the war effort. — H.L.

From plan to reality

My HO scale National Docks track plan gets a lot of harbor modeling into a modest space. From ships and barges to big industries to switching and transfer runs, there are many opportunities to add details and run trains.

I hope this plan will inspire you to give waterfront modeling a try. Having completed one harbor layout already, I can't wait to start work on the National Docks Ry. **MR**

Ahead of its time

A forward-thinking 1950s John Armstrong layout design inspired these two plans

By Robert L. Warren

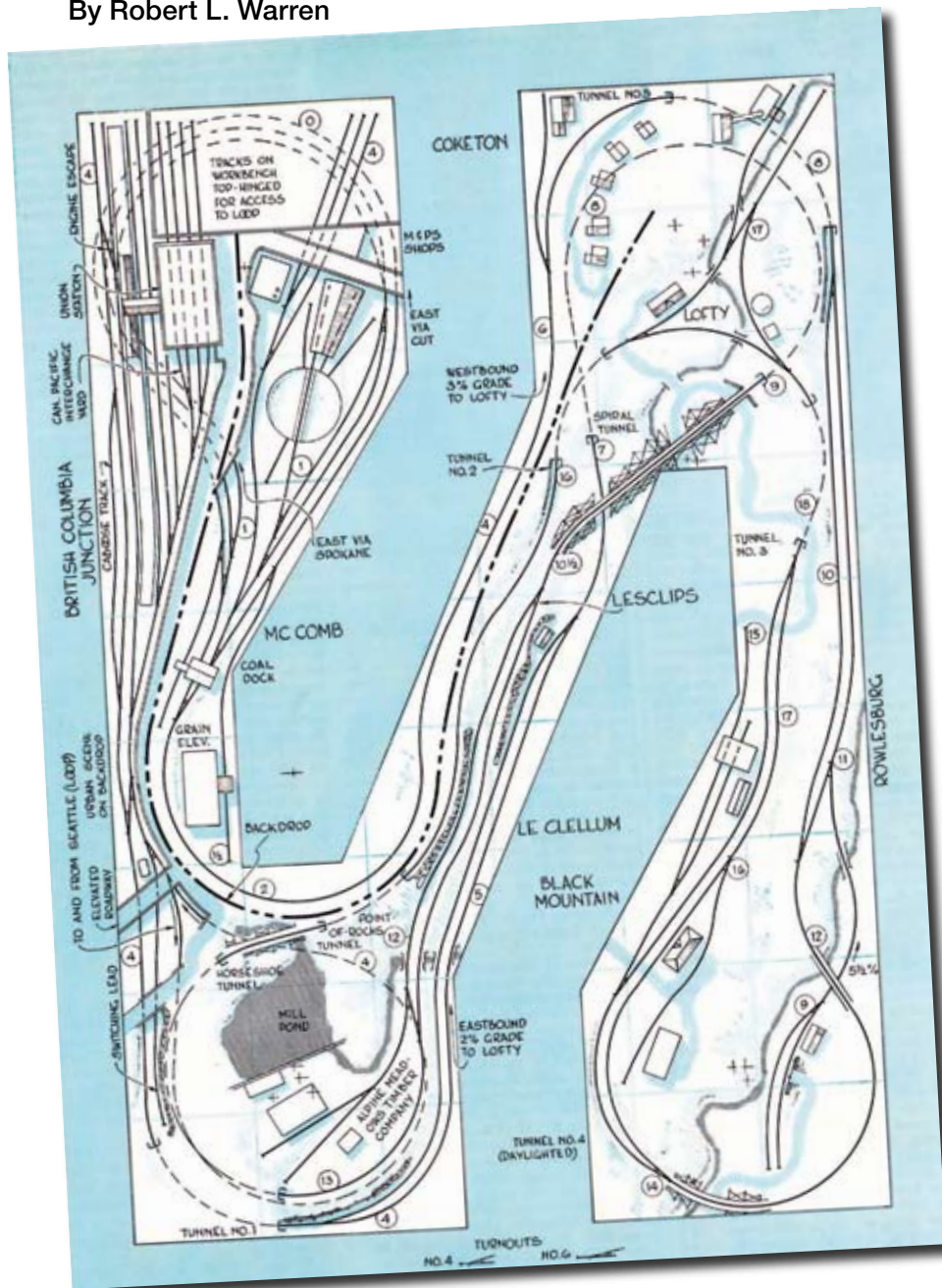

The Montana & Puget Sound. John Armstrong's 1959 track plan featured many innovative ideas, including walkaround design, a linear main line, and some hidden staging. Those concepts are now common in modern layout designs.

I've often thought that one of John Armstrong's best track plans is his Montana & Puget Sound (M&PS) design, first featured in the December 1959 *Model Railroader*. This 12 x 18-foot S-shaped layout featured Pacific Northwest railroading set in the Cascade Mountains and incorporated several layout design ideas that we take for granted today, but which were innovative in 1959.

John's plan made economical use of a 16 x 22-foot room thanks to its clever walk-in, no-duckunder design. The fact that operators could follow their trains around the perimeter of the entire layout, coupled with John's decision to use a scene-dividing backdrop, makes the M&PS seem much larger than it really is. Also, John gave the layout a three-track staging loop at one end for easier point-to-point operation.

Because of these attractive features, I'm surprised more people haven't used the plan for their own layouts – perhaps it's because John's design really was ahead of its time and model railroading had some catching up to do.

A lot has changed in the hobby in the 49 years since the M&PS plan first appeared. Digital Command Control (DCC), wireless throttles, N scale, multi-level layouts, and vast staging yards have become commonplace items. With all of these improvements in the hobby, the time is ripe for the M&PS plan to be revisited and updated.

New twists on an old theme

Using the basic shape and walk-in feature of the M&PS design as a starting point, I drafted two new plans – one in N scale, the other in HO. Both plans use the same 16 x 22-foot room, but I made several modifications to enhance the layout's operation. The first variation was to shorten the upper-right end of the railroad so I could expand the benchwork to run along the top wall. The second modification was to add an upper level, creating space for a major yard and more staging. To do this I used the mushroom design, a concept popularized by John in his later track plans and first featured in his October 1987 MR article, "Meet the Mushroom."

Plan 1: A granger railroad

Since John's layout already explored mountain railroading in the Cascades, I wanted a different theme for mine. I selected a granger railroad, the Chicago, Rock Island & Pacific (CRI&P), setting it in the 1950s. The Rock Island served a number of major cities, including Chicago, Memphis, Minneapolis,

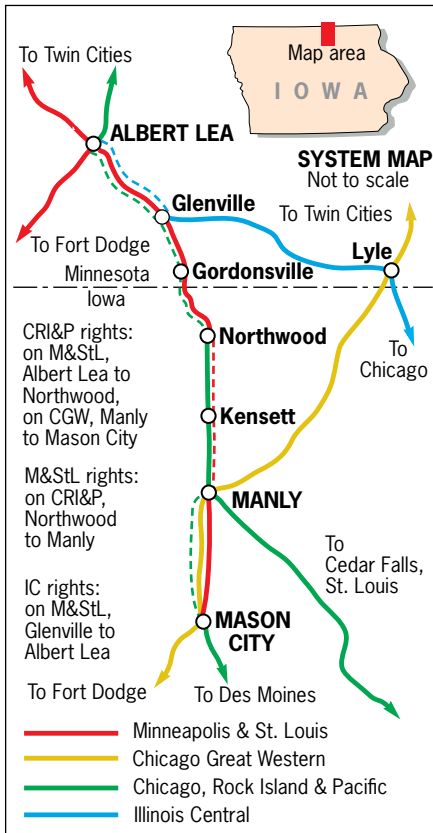

Illustration by Robert Wegner

and St. Louis, and extended as far as Colorado, New Mexico, and Texas. Also of interest is the fact that the CRI&P railroad owned one of nearly every first-generation diesel locomotive made by Electro-Motive Division (EMD) and Alco, making for a varied roster.

For the track plan, I chose to represent parts of the Rock Island's line from Manly, Iowa, to Albert Lea, Minn. As shown in the map above, the Rock Island shared this 30-mile stretch with the Minneapolis & St. Louis (M&StL), and the Illinois Central (IC) used a portion of it too.

Just north of Manly, Iowa, was a major junction. Here, the CRI&P and the M&StL split. The Rock Island continued southeast on its own tracks to places such as Cedar Rapids, Iowa, and St. Louis. The M&StL's main line continued south to Mason City, Iowa. The Chicago Great Western (CGW) crossed the CRI&P's line at Manly, and the CRI&P used the CGW's line to get to Mason City, before returning to its own tracks heading south to Des Moines.

Modeling the line in N scale

By working in N scale, I was able to fit a good portion of the Manly-to-Albert Lea main line into the original plan's 16 x 22-foot room. This right-of-way saw a number of colorful daily passenger trains on the CRI&P, so to



The Chicago, Rock Island & Pacific owned a colorful fleet of locomotives in the 1950s, as shown by this pair of EMD GP7s in red, white, and black passing through Stockton, Iowa, on a sunny afternoon in 1952. Charles H. Kerrigan photo

accommodate them I used 22"-radius curves on the main line and the helix (the staging loops use 18" curves).

Though the plan offers a loop for display-running, I designed it for point-to-point operation, using a DCC system and wireless throttles to take full advantage of its walkaround features. I also included plenty of staging. In addition to the main yards on the upper and lower levels, there are other staging tracks on the layout representing the various connecting railroads, including the IC and the CGW. The second track on top of the helix provides staging for the M&StL branch line to Fort Dodge and doubles as the Albert Lea yard lead.

The plan's only major compromise is the IC connection, which should be at Glenville, Minn. I had to push this junction over the border into Iowa to take advantage of staging space for the IC train under the helix.

Operating the line

During a typical operating session the Rock Island would see one manifest freight in each direction and two locals. Most of the switching on the modeled portion of the line was handled by the M&StL, but the CRI&P had industries to work at Glenville. An additional Rock Island train operated each way between Minneapolis and Cedar Falls as well.

The CRI&P ran two daily passenger trains out of the Twin Cities through this region. The *Twin Star Rocket* ran to Houston as train 507, with its counterpart, 508, running north. Train 509, the *Kansas City Rocket*, ran to Dallas, with 510 being its northern side. The trains made station stops at Manly and Albert Lea, and according to the 1959 timetable, 507, 508, and 509 called at those

towns during the day within six hours of each other.

The M&StL also ran a daily manifest freight and a local each way over the line. The locals would handle the switching duties at Northwood and Kensett. An additional freight ran from Minneapolis to deliver cars at Albert Lea and then return.

The Albert Lea job would have a yard crew to handle local switching and sort the interchange traffic with the IC. An additional M&StL train worked the Fort Dodge branch line. The M&StL also had a daily local passenger train in each direction, consisting of a gas-electric coach and trailer.

An operating session would see one IC train running up the branch from Chicago via Waterloo, Iowa, (staging) to interchange cars at the Albert Lea yard. The train would then return to home rails via Glenville. The Chicago Great Western would run one daily train in each direction as well, switching the industries in Manly as needed.

Plan 2: Climbing mountains

If you're looking for a coal-hauling mountain railroad to model, the Western Maryland's line northeast out of Elkins, W.Va., is hard to beat. Heavy unit coal trains with long strings of engines on the head end, mid-train helper action, and rugged scenery are all part of the WM's charm. That's why I chose it as the subject for this HO plan.

I've designed an HO scale layout for the same size room and based it on the Western Maryland's Thomas Subdivision running from Elkins to Thomas, W.Va. Like the Rock Island plan, I used the principal shape and walkaround features of John Armstrong's M&PS design as a starting point. I also carried over several elements from my Rock

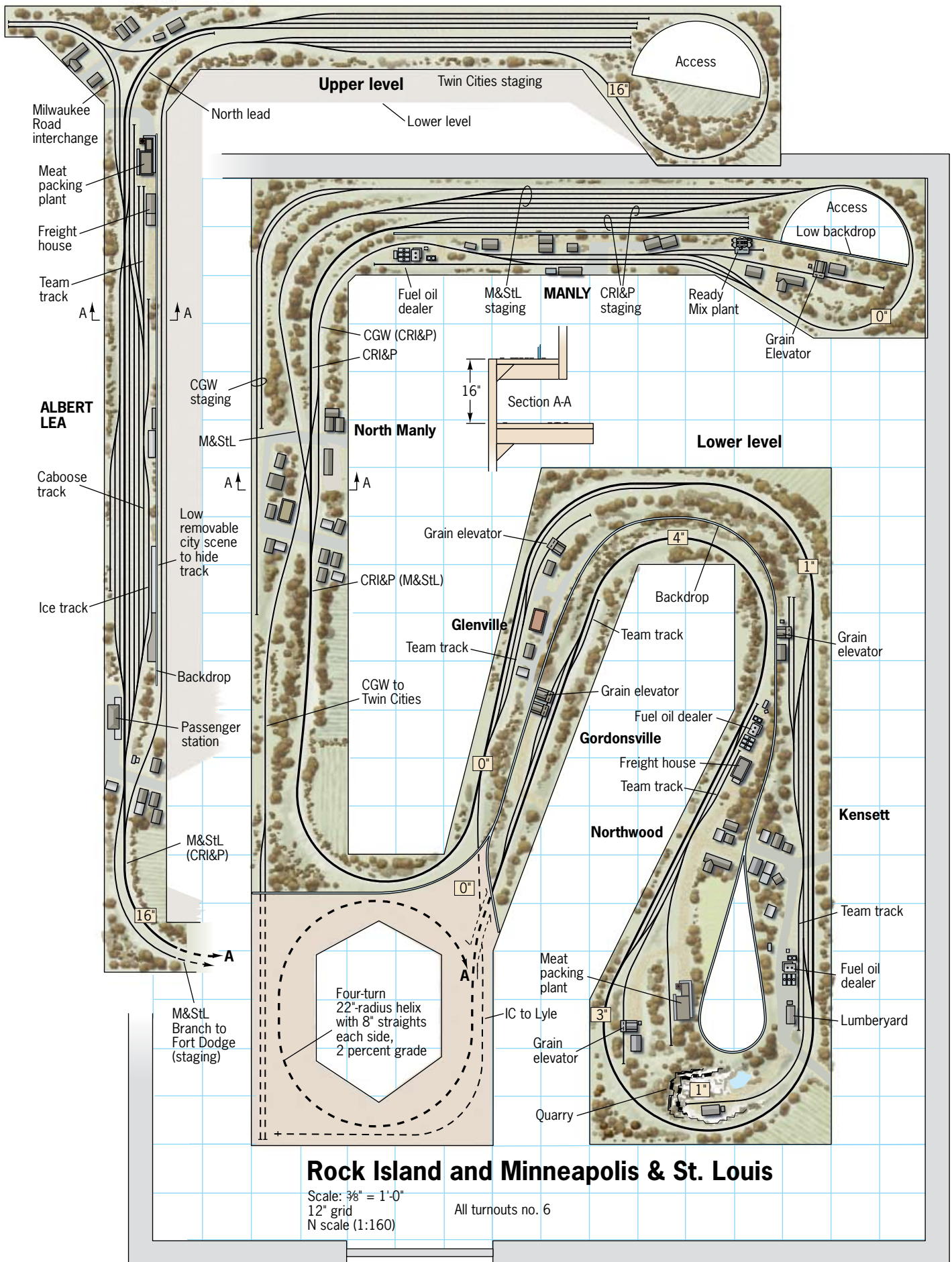

Illustration by Rick Johnson and Robert Wegner



A trio of WM Alcos leads an eastbound coal train out of the yard at Elkins on its way to Thomas. The WM collected loads of coal from various mines and brought it to Elkins. There, crews weighed and sorted the cars into outbound trains such as the one shown above. Frank E. Shaffer photo

Island plan, including staging tracks along the west wall and the multi-level design, to give more yard space. However, this time I didn't need a helix.

Since my Western Maryland design was made to haul coal up big hills, I used a steeply graded main line (just over 5 percent on Black Fork Hill) to connect the yard at Thomas on the upper level to the rest of the layout. As it was not uncommon for the WM to use two to four locomotives on the head of a train and three to six mid-train helpers, I felt the steep grade was justified. And, thanks to Digital Command Control (DCC), you can easily add helpers to a train.

A look around the layout

My Thomas Subdivision plan starts on the lower level at Elkins. This is the biggest town on the layout, and it includes a yard, passenger station, and engine terminal. There's also a scale

track for weighing loaded cars, a small car shop, and several industries. The staging yard for all points west is hidden behind the passenger station.

Going east from Elkins, the main line starts a 1.4-percent climb, passing through Montrose, on its way to Parsons. Because of the small yard and the number of industries in Parsons, I made the tracks in town level. The town also has several industries, including the largest on the layout, a Kingsford Charcoal plant.

Continuing east from Parsons, the mainline grade kicks into high gear, requiring mid-train helpers through Black Water Canyon and up Black Fork Hill to Thomas on the upper level. I've included a small coal loader and four-track yard at Thomas, but the yard could be bigger if you have the space.

From Thomas, the main line continues into the upper staging yard, representing the rest of the WM east.

Operating the Thomas Sub

Traffic on the line is fairly simple: coal moves east, empty hoppers come west. The Western Maryland had three branch lines west of Elkins, and the railroad collected coal loads at Elkins, weighed it, and blocked it for shipment.

Normally three daily freights were dispatched from Elkins. The first one, called the East Local, was actually a through freight. To keep the yard at Elkins fluid, the East Local often left town overloaded and would set out cars at Montrose to reduce tonnage. The second train out of Elkins picked up the loads set out at Montrose and continued up to Thomas.

On the model, I'd make up the East Local at Elkins with excess cars on the head of the train, mid-train helpers behind them, and two cabooses. At Montrose I'd have the head-end power set out the cars while the helpers held the rest of the train on the grade. The siding would need to have some sort of brake to prevent the setouts from rolling away. When the train reached Thomas, the helpers would take their caboose and return to Montrose to assist the second train up the grade.

The second train would carry general freight from Elkins and Durbin and any additional coal traffic. At Montrose, the train would pick up the East Local's setouts and cut the helpers into the middle of its train. Once the train arrived in Thomas, the helpers would then return to Elkins.

The local industries between Elkins and Parsons are worked by the Parsons Turn. Though Parsons has a tannery, team track, and the Kingsford plant, I added a sawmill at Montrose to provide more work for the turn.

Elkins would have its own yard crew to sort and weigh loads coming in from the mines, make up outbound trains, and switch the local industries, including the car shop.

A daily westbound passenger train would also run from upper staging and terminate at Elkins. This train would then be turned around and sent back later in the day. The consist on the Western Maryland generally included a Railway Post Office (RPO) and a coach; the train was pulled by a "hammerhead" Alco RS-3. (There was a steam generator under the taller-than-normal short hood, giving the engine its nickname.)

Lessons from John Armstrong

John Armstrong was a master when it came to getting the most out of an available space. Whether you consider building either of my two plans or de-

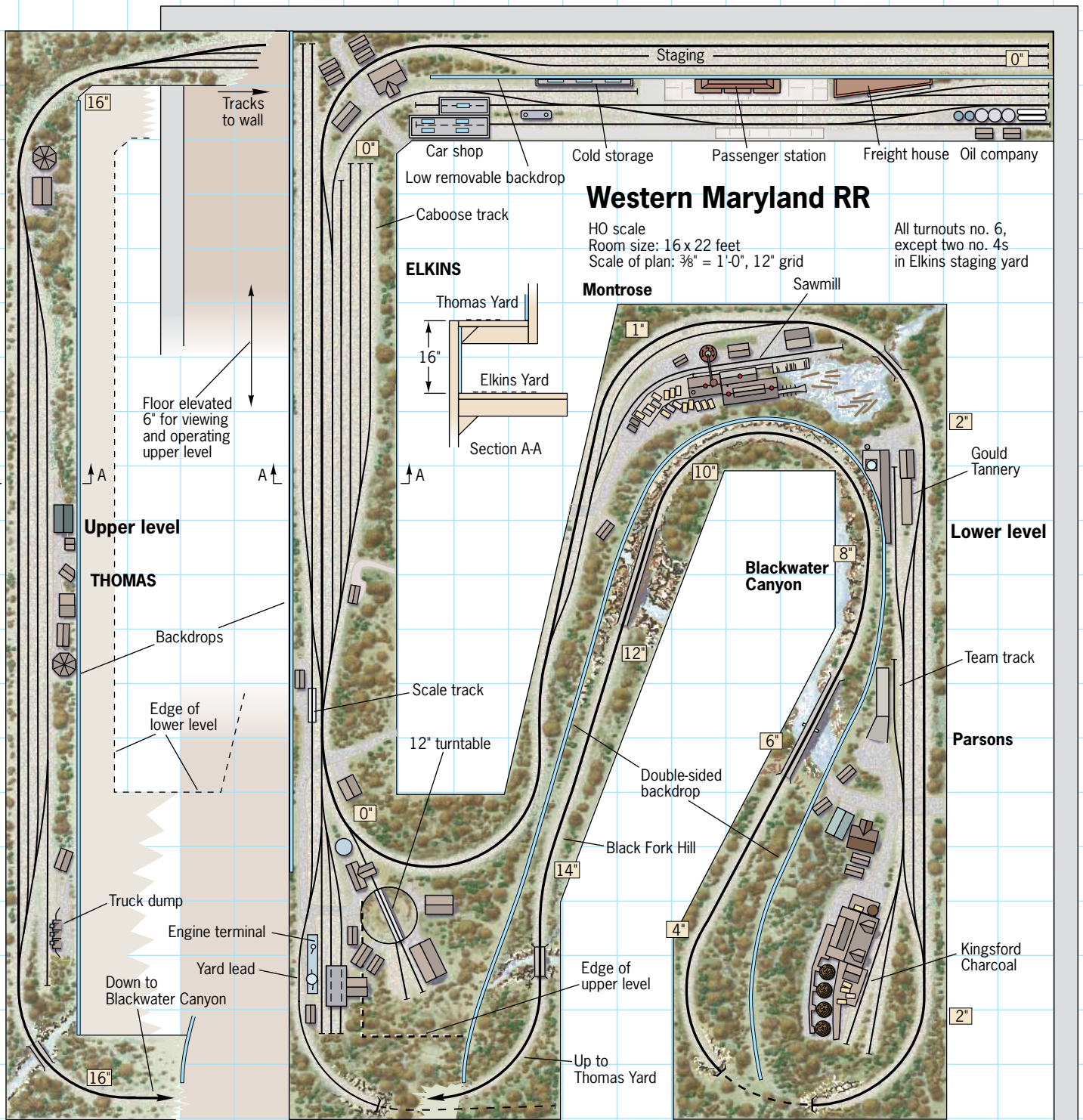

Illustrations by Robert Wegner



side to design your own model railroad from the ground up, there's a lot of things you can learn about layout design simply by studying one of John's plans. [MR](#)

To purchase more John Armstrong plans, see the four-volume Information Station downloadable PDF series The Best of John Armstrong. Click on "Downloads" at [ModelRailroader.com](#)