

Gull Pond Station Interior

by Edward A. Stinson
Wiscasset, Maine

The details that are shown here apply to the station at Gull Pond (plan set #28-A). However, most of what is shown can be applied to other structures, and is therefore generally useful.

x 3/4" x 3/4" block of wood, a piece of 1/8" dowel, and some pins. Paint this black. When it is dry, paint just the pin-heads white with typewriter correction fluid. Glue the typewriter to the deck when it is complete.

Make the stove and paint it flat black. When it's dry, glue it in place in the center of the waiting room. Make sure to align the stovepipe with the stack on the station roof.

CONSTRUCTION

Cut a piece of 1/4" plywood, 5 5/8" x 11 7/8". Notch the corners so that it fits just inside the Gull Pond station. Sheath the top surface with 1/32"-thick x 3/8"-spaced scribed wood. Using the floor plan, locate the position of the interior walls. Cut the walls from 1/8"-thick plywood. Sand them smooth and finish to suit. Glue the walls in place.

OTHER DETAILS

Add a baggage wagon to the outside of the station to complete the basic detailing. Begin it by gluing 1/8" x 3/16" stripwood around the outside edges of a piece of 1/8" x 1 1/2" x 3 1/2" plywood. Cut the axle supports from 1/8" x 5/8" stock. Glue these in place on the bottom.

Make two doors according to the plan (apply stripwood to both sides of the plywood door blank). Glue these in place. Cut the lamp support from 1/8" x 1/4" strip. Drill 1/8"-diameter holes in each end. Nail and glue this in place. Lights can be added by fitting two grain-of-wheat (GOW) bulbs into the holes in the lamp support. Feed the wire leads down the wall and through the floor to your power source. If you want to gild the lily, make up two lamps as shown on the plan. Paint the tops of the visors green. Glue them into holes in the support and fit them with GOW bulbs.

Cut two 3/16"-square x 1 1/2"-long axles. Glue the rear axle to the support. Use the other axle to make up the front yoke with attached handle. Paint this and the main body of the baggage wagon dark green. When dry, drill a 1/16" diameter hole in the front axle support. Pin the front axle in place with a #18 x 1/2" escutcheon pin.

Paint four 1"-diameter cast, spoked wheels red. When dry, fit them to the axles using #18 x 1/2" escutcheon pins. Use 3/64"-diameter pilot holes to avoid splitting the axles. Make up the two end racks from stripwood. These should be left natural. Glue them in place, adding the .03" diameter wire U-bolts when dry.

FURNITURE

Make up the bench seats using 1/16" strip and sheet. Finish these with golden-oak stain and clear lacquer. Now make up the cabinet and lavatory. Finish these in the same manner as the bench seats. When dry, glue them in place. Cut a 15/8" x 2 1/2" piece of 1/8" plywood to act as the desk top. Give this a natural finish and glue it into the bay window.

Cut a piece of wood 1/16" x 3/4" x 1". Round the corners and give it a natural finish. Glue this in at the base of the counter opening. Make a chair and a waste basket and paint them gray or green. Make the typewriter from a 3/8"

This sheet is a supplement to the June 1997 issue of *Garden Railways* magazine. While supplies last, extra copies of these drawings can be had by sending \$1.50 per set (\$2.00, foreign) to: Sidestreet Bannerworks, PO Box 61461, Denver CO 80206 USA. For those not possessed of the energy or equipment, a complete kit of parts is available for \$29.95 + \$5 s&h from Northeast Narrow Gauge, PO Box 191, Wiscasset ME 04578.

© 1997 by Garden Railways and Northeast Narrow Gauge. These drawings may be photocopied by individual modelers for their own personal use. Copying for any commercial use or for distribution is prohibited without written consent from the publisher.

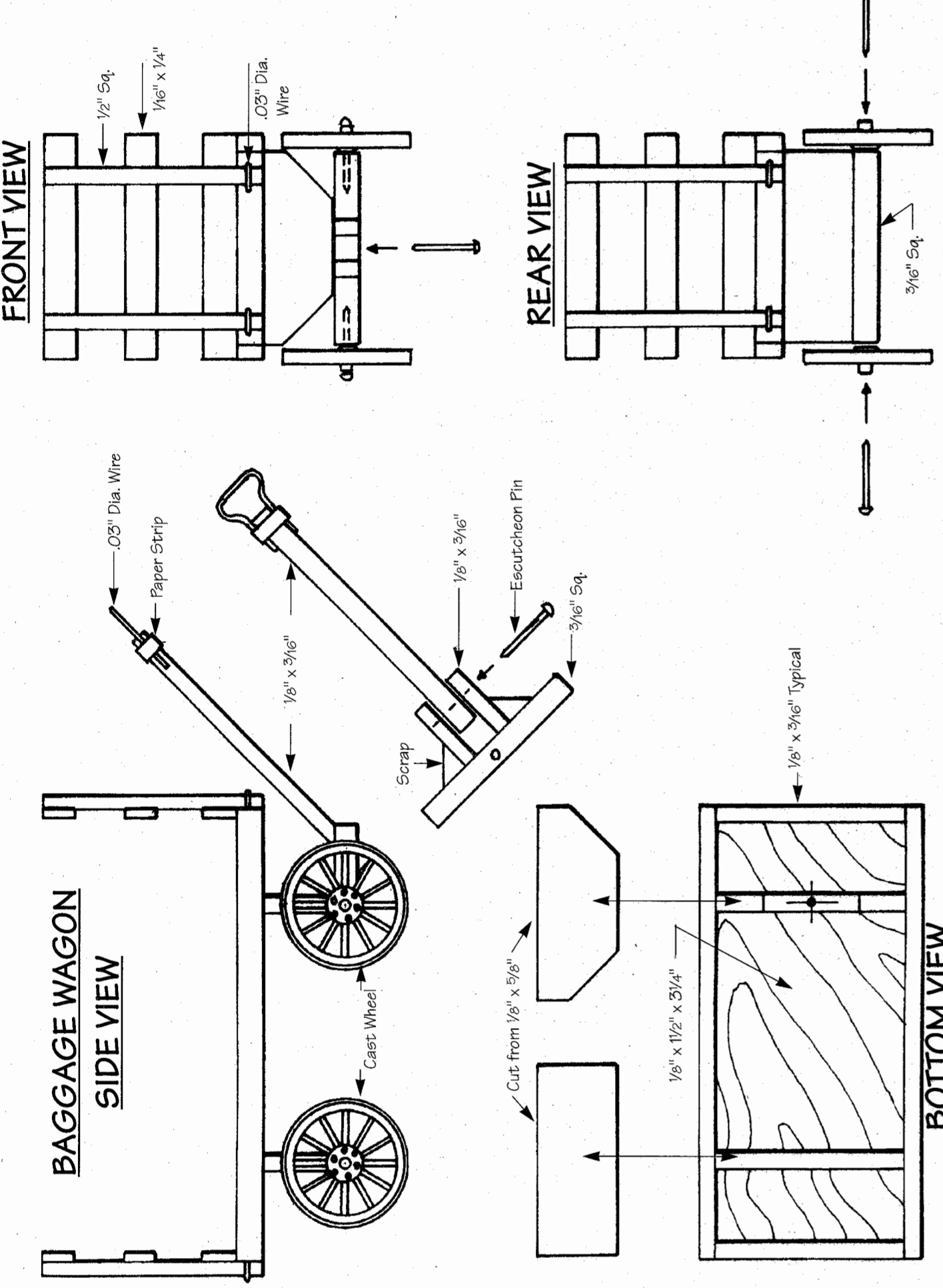

BENCH SEAT

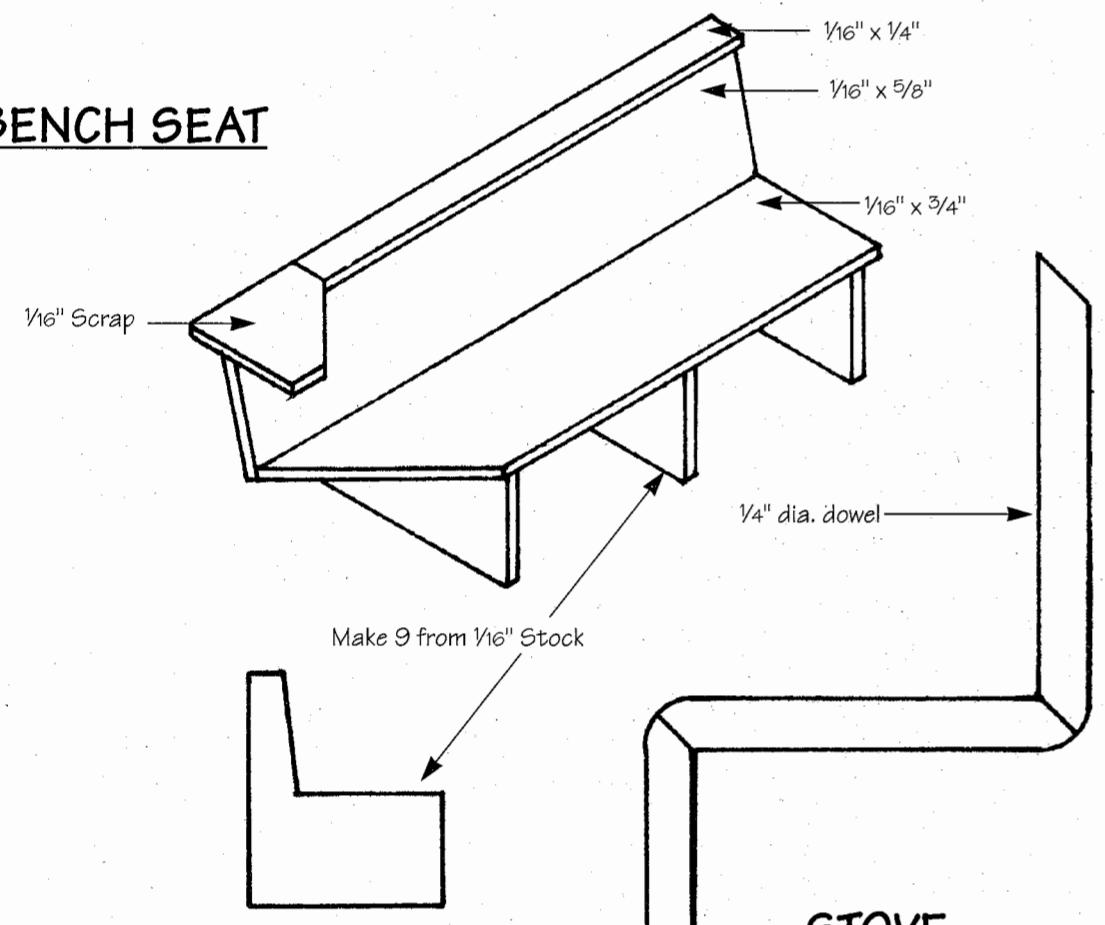

CABINET

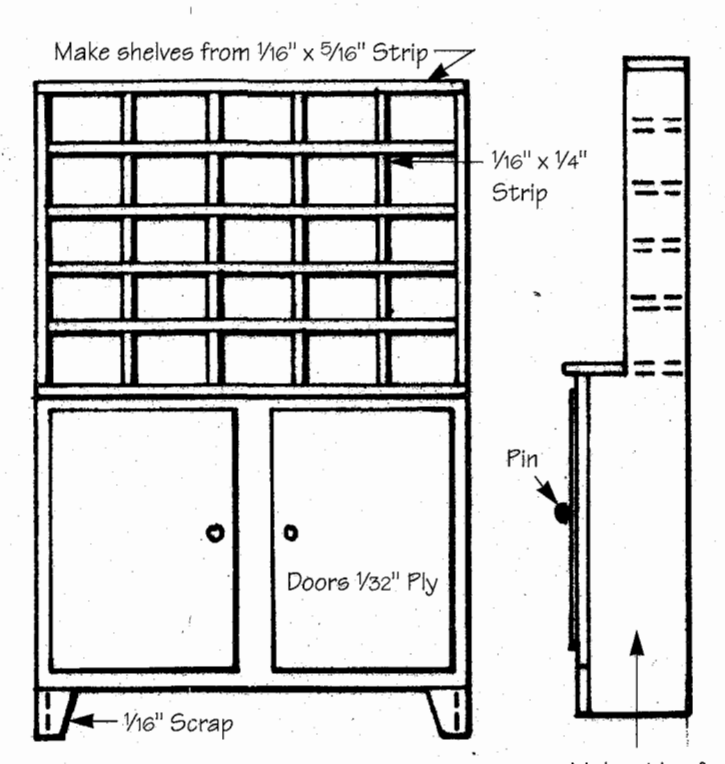

LAVATORY

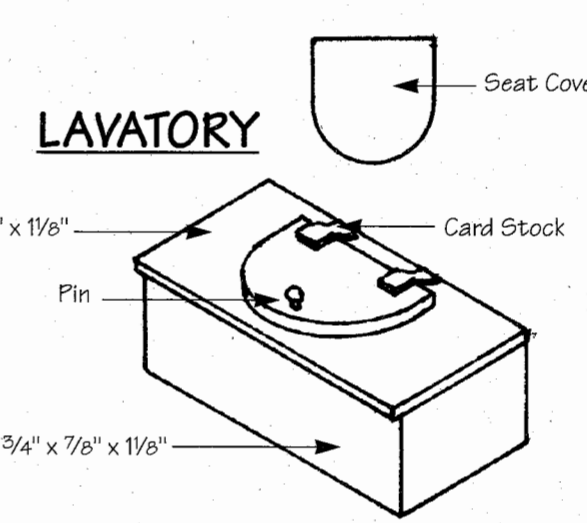

WASTE BASKET

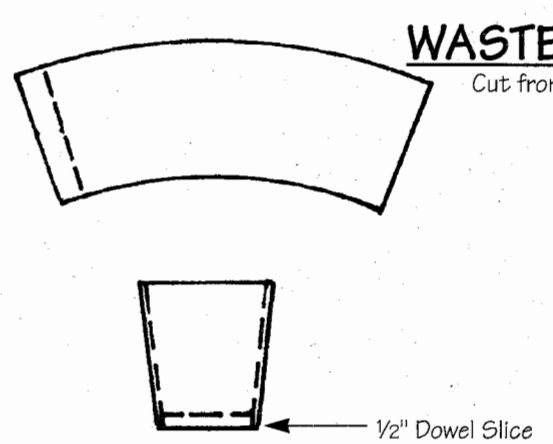

STOVE

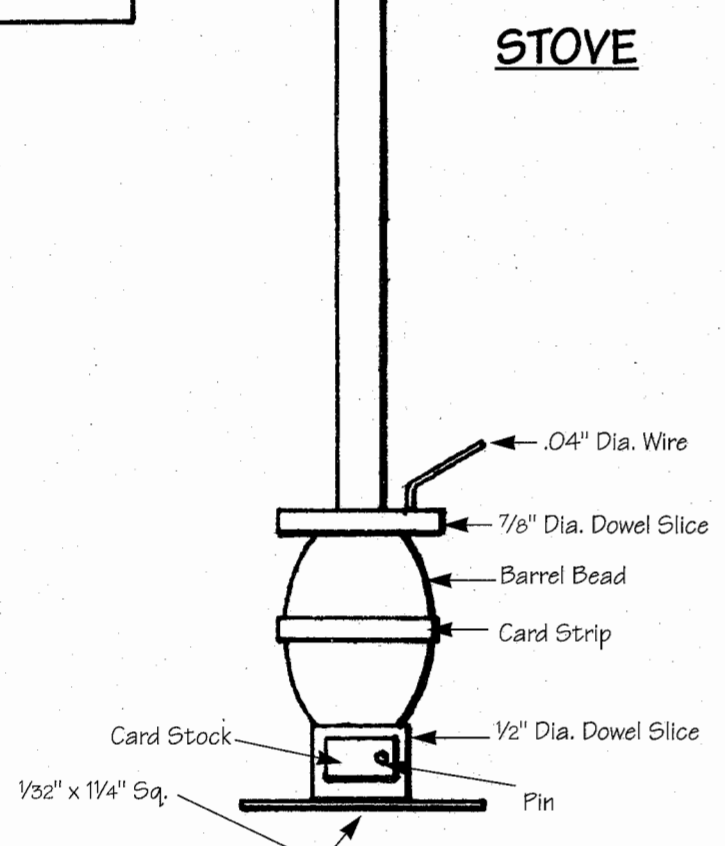

CHAIR

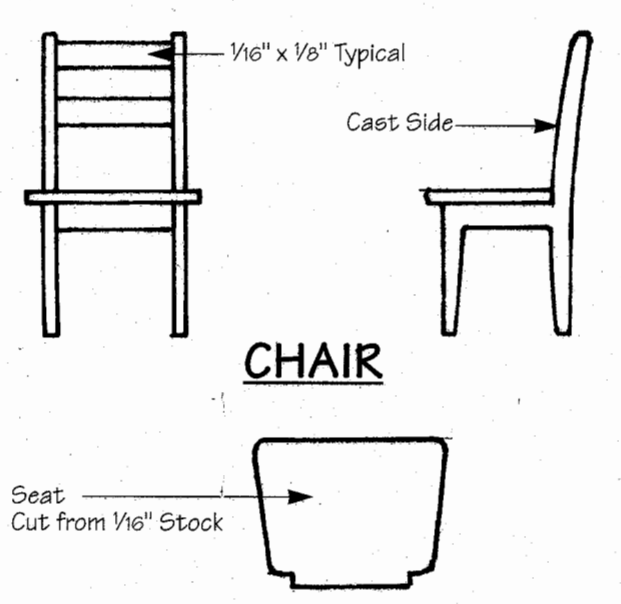

TYPEWRITER

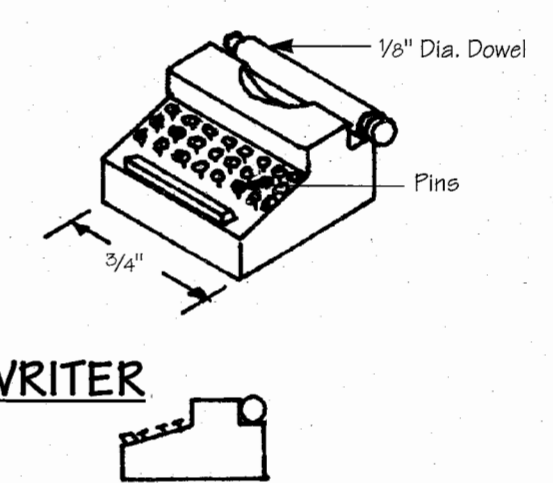

FLOOR PLAN

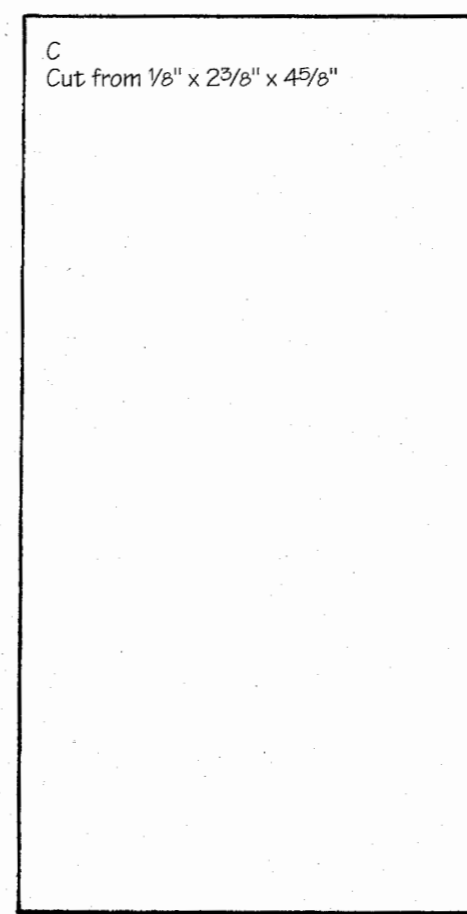
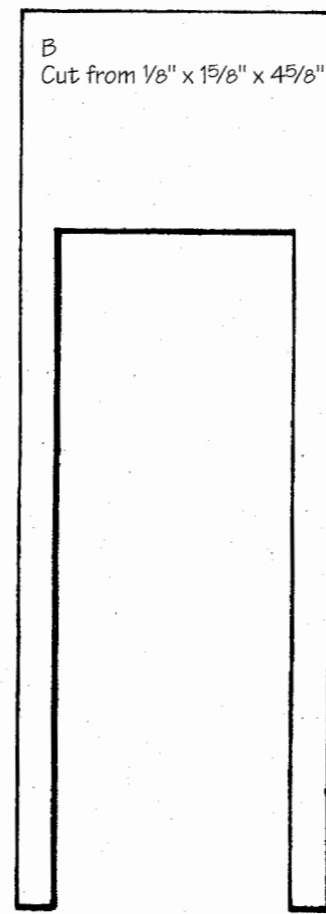
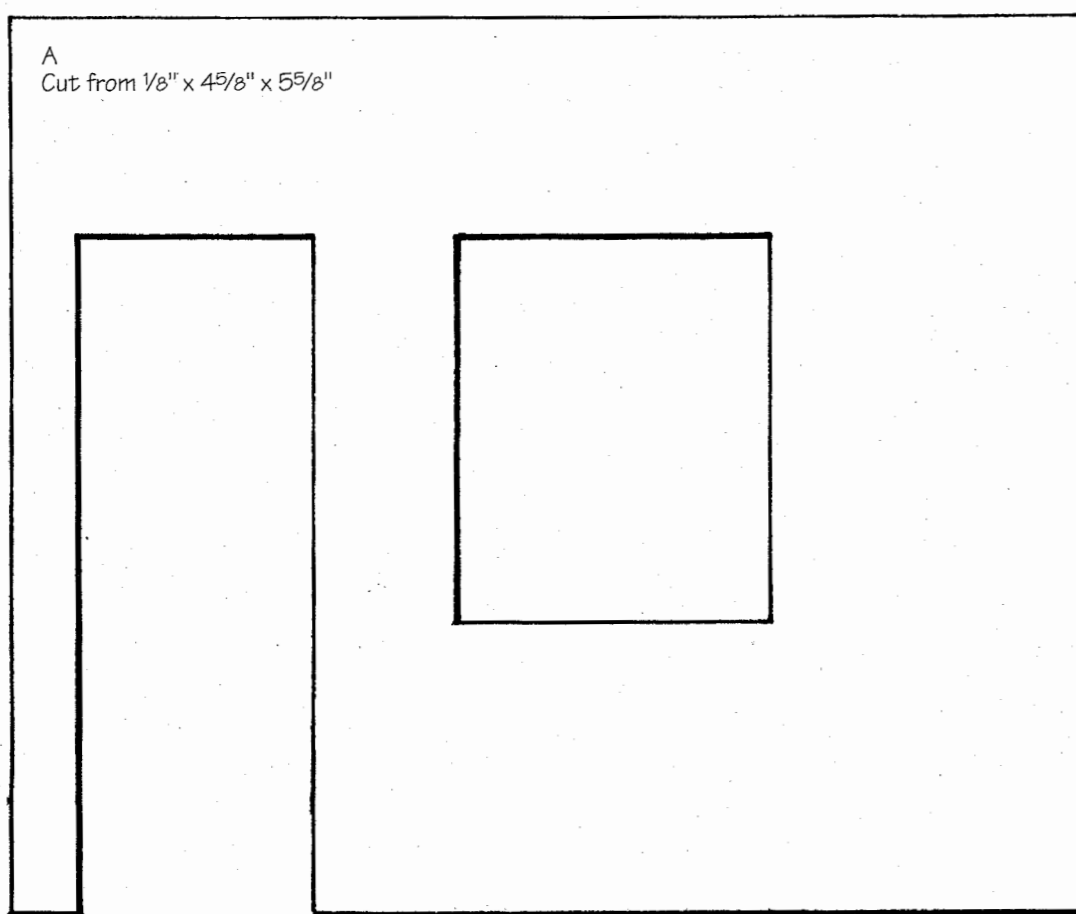
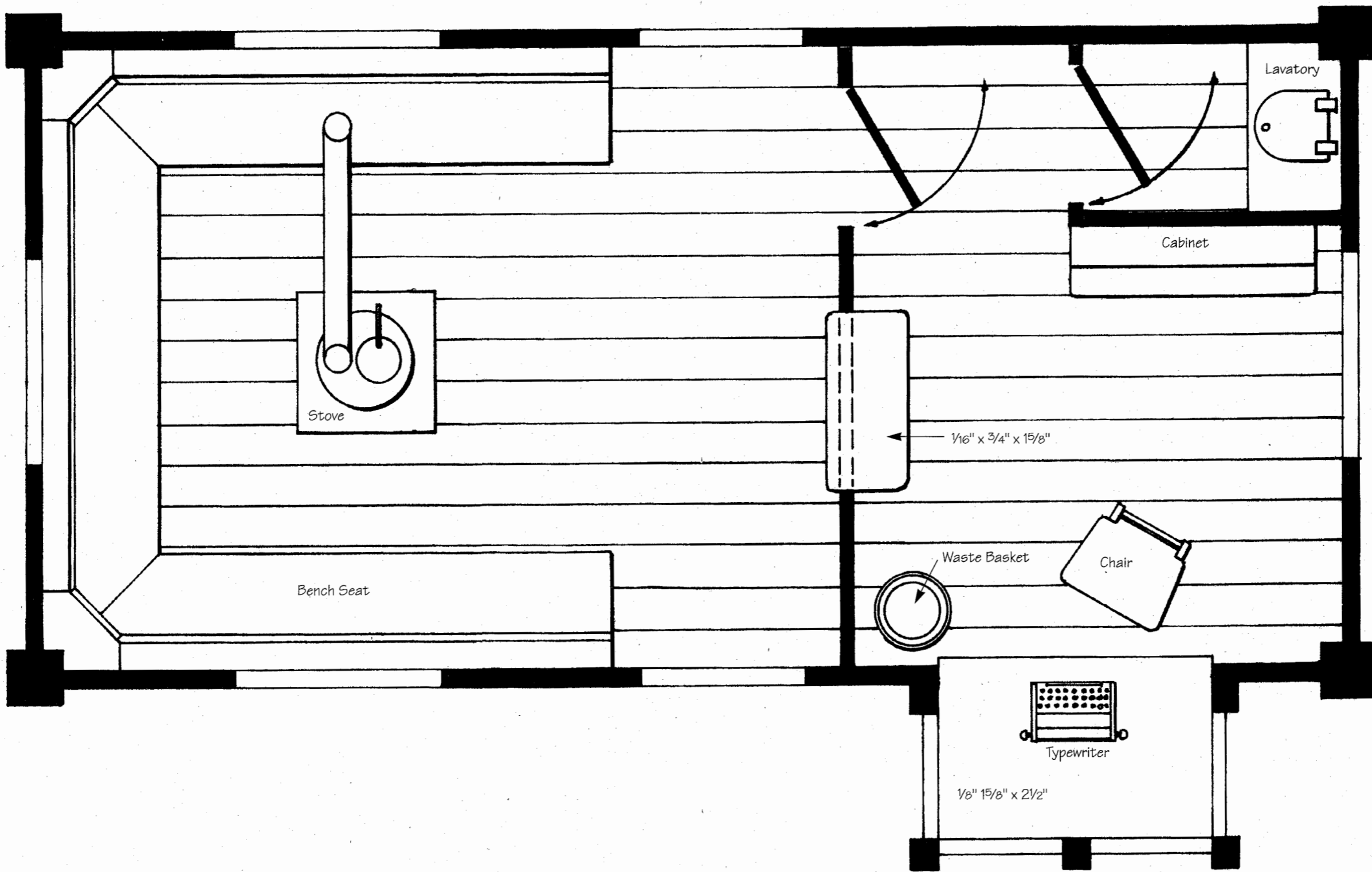

DOOR

Make 2

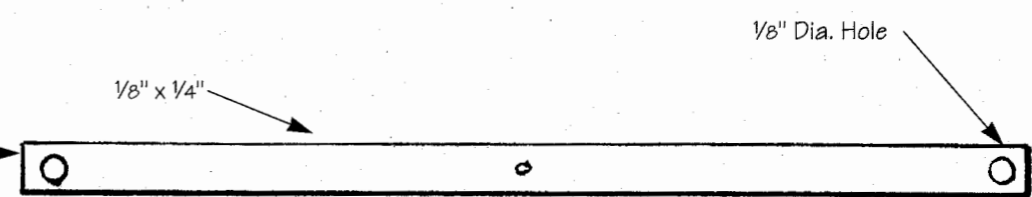
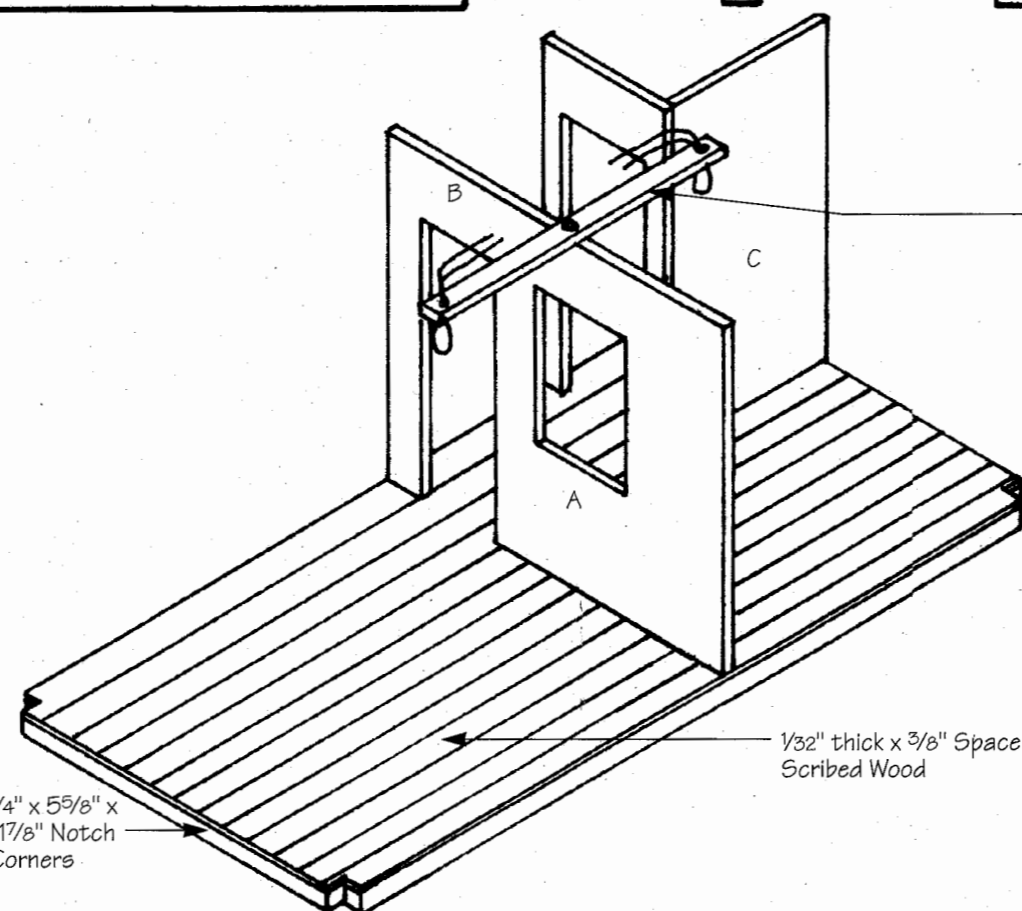
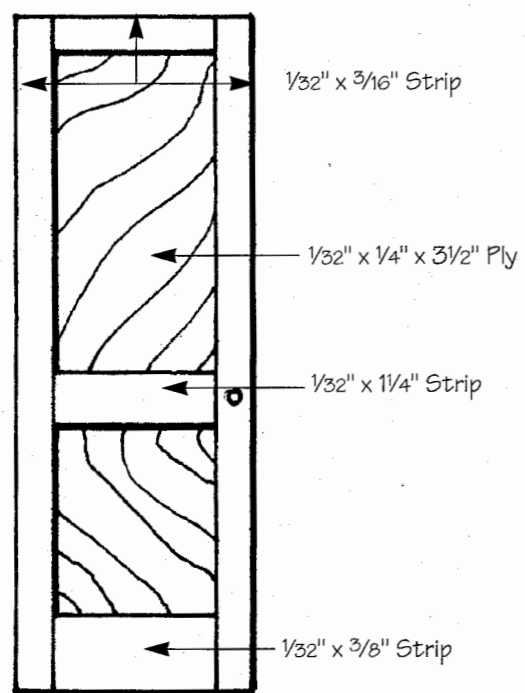

LAMP

Make 2

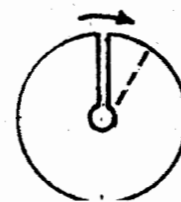
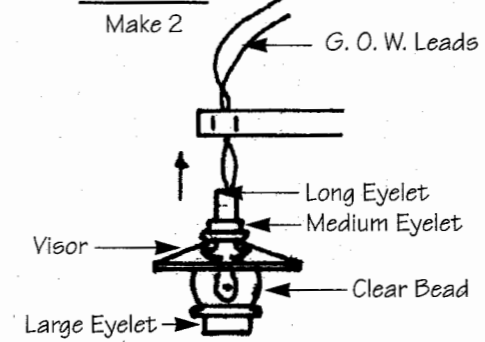

Cut Visor from Card Stock